

Installation manual
(Translation of original language)

EN



N421063A - Rev.02 - 11/2024

2.0 CEILING

Horizontally air conditioning
surface-mounted

First of all, we would like to thank you for having chosen one of our units.

As you will realise, you have made a winning choice by purchasing a product that represents the state of the art in domestic air-conditioning technology.

Thanks to the product you have purchased and by following the suggestions in this manual, you will benefit from optimal environmental conditions with the lowest possible energy investment.

INNOVA S.r.l.

Compliance

This unit complies with European directives:

- Low Voltage Directive 2014/35/EU by transposition of the following technical standards: EN 60335-1:2012 + EN 60335-2-80:2003
- EMC Directive 2014/30/EU, by transposition of technical standards: EN 55014-1:2021 + EN 55014-2:2021
- + EN IEC 61000-3-2:2019+A1:2021 + EN 61000-3-3:2013+A2:2021
- RoHS Directive 2011/65/EU by transposition of the following technical standards: EN IEC 63000:2018
- European ErP Ecodesign Regulation No. 1254/2014

Markings



CONTENTS

Compliance 2

1. General information 4

- 1.1 About the manual 4
- 1.2 General warnings 5
- 1.3 Basic safety rules. 5
- 1.4 Disposal 6

2. Product introduction 7

- 2.1 Identification 7
- 2.2 Destination of use 7
- 2.3 Description of the appliance 7
- 2.4 List of external components 8
- 2.5 List of internal components 9

3. Installation 10

- 3.1 Preliminary warnings 10
- 3.2 Reception 10
- 3.3 Dimensions and weights with packaging 10
- 3.4 Handling with packaging 11
- 3.5 Storage. 11
- 3.6 Unpacking 11
- 3.7 Handling without packaging. 12
- 3.8 Installation site. 12
- 3.9 Minimum installation distances. 14
- 3.10 Positioning 15
- 3.11 Condensate drainage provision 21
- 3.12 Electrical connections 23

4. The on-board display and the remote control 26

- 4.1 Interface 26
- 4.2 Main functions 28
- 4.3 Warnings. 29

5. Start-up. 31

- 5.1 Preliminary warnings 31
- 5.2 First start-up 31
- 5.3 Plant delivery 32
- 5.4 Switching off for extended periods 32

6. Maintenance. 33

- 6.1 Preliminary warnings 33
- 6.2 Routine maintenance 33

7. Faults and remedies 35

- 7.1 Preliminary warnings 35
- 7.2 Troubleshooting table. 35
- 7.3 Table of alarms indicated by the display. 36

8. Technical information 37

- 8.1 Technical data. 37
- 8.2 Dimensions 39

1. GENERAL INFORMATION

1.1 About the manual

This manual was written to provide all the explanations for the correct management of the appliance.

- ⚠ This instruction manual is an integral part of the appliance and must therefore be kept in a safe place and must ALWAYS accompany the appliance even if it is passed on to another owner or user, or transferred to another plant. If it is damaged or lost, download a copy from the website.
- ⚠ Read this manual carefully before proceeding with any operation and follow the instructions in the individual chapters.
- ⚠ Specific warnings are given in each chapter of the document and should be read before starting operations.
- ⚠ The manufacturer accepts no liability for damage to persons or property resulting from failure to observe the regulations contained in this booklet.
- ⚠ This document is confidential under the terms of the law and may not be reproduced or passed on to third parties without the express authorisation of the Manufacturer.

Editorial pictograms

The pictograms in the following chapter provide quick and unambiguous information necessary for the correct and safe use of the machine.

Related to safety

⚠ High risk warning (bold text)

- The operation described above presents a risk of serious physical injury, fatality, major damage to the appliance and/or to the environment if not carried out in compliance with safety regulations.

⚠ Low risk warning (plain text)

- The operation described above presents a risk of minor physical injury or minor damage to the appliance and/or to the environment if not carried out in compliance with safety regulations.

🚫 Prohibition (normal text)

- Marks actions that are prohibited.

📌 Important information (bold text)

- This indicates important information that must be taken into account during the operations.

In the texts

Purpose of the actions

- ▶ Actions required
Expected responses following an action

- Lists

In the figures

- 1 The numbers indicate the individual components.

A Capital letters indicate a combination of components and dimensions.

- ① The white numbers in black marks indicate a series of actions to be carried out in sequence.
- Ⓐ The black letter in white identifies an image when there are several images in the same figure.

Pictograms on the product

Symbols are used in some parts of the appliance:

Related to safety



Read the instruction manual

Read the instructions carefully before performing any operation on the appliance.



Instruction manual

Read the information available in the technical documentation of the appliance.



Attention electrical hazard

- Warns relevant personnel of the presence of electricity and the risk of electric shock.

Recipients

User

Non-expert person capable of operating the product in safe conditions for people, for the product itself and the environment, interpreting an elementary diagnostic of faults and abnormal operating conditions, carrying out simple adjustment, checking and maintenance operations.

Installer

Expert person qualified to position and connect (hydraulically, electrically, etc.) the unit to the plant; this person is responsible for handling and correct installation according to the instructions provided in this manual and the national standards currently in force.

Service

Expert and qualified person authorised directly by the Manufacturer to carry out all routine and supplementary maintenance operations, as well as every adjustment, check, repair and replacement of parts necessary during the life of the unit.

Organisation of the manual

The manual is divided into sections each dedicated to one or more target groups.

General information

It addresses all recipients.

It contains general information and important warnings that should be known before installing and using the appliance.

Product introduction

Addressed to all recipients, contains general information on the product.

Installation and Operation

It is addressed exclusively to the installer.

Contains specific warnings and all information necessary for positioning, mounting, connecting the device and operation.

Commissioning, maintenance and troubleshooting

They are addressed exclusively to the Authorised Service Centre.

It contains specific warnings and useful information for the most common commissioning and routine maintenance.

Technical information

It addresses all recipients.

It contains detailed technical information about the appliance.

1.2 General warnings

- ⚠ Specific warnings are given in each chapter of the document and should be read before starting operations.
- ⚠ All personnel involved must be aware of the operations and dangers that may arise when beginning all unit installation operations.
- ⚠ Installation performed outside the warnings provided in this manual and use of the appliance outside the prescribed temperature limits will invalidate the warranty.
- ⚠ Any contractual or extra-contractual liability for damage caused to persons, animals or property, due to installation, adjustment and maintenance errors or improper use is excluded. All uses not expressly indicated in this manual are not permitted.
- ⚠ The installation of the appliances must be carried out by a qualified company which, on completion of the work, will issue a declaration of compliance to the person in charge of the plant in accordance with the regulations in force and the instructions provided in the instruction booklet accompanying the appliance.
- ⚠ First start-up and repair or maintenance operations must be carried out by the Authorised Service Centre or by qualified personnel following the provisions of this manual.
- ⚠ Do not modify or tamper with the appliance as this can lead to dangerous situations.
- ⚠ Use suitable personal protective clothing and equipment during installation and/or maintenance operations. The Manufacturer is not liable for the non-observance of the current safety and accident prevention regulations.
- ⚠ In case of liquid or oil leaks, isolate the main power supply of the system and close any water valves. Promptly contact the Authorised Service Centre or professionally qualified personnel, and refrain from personally intervening on the equipment.
- ⚠ When replacing components, use only original spare parts.
- ⚠ The Manufacturer reserves the right to make changes to its models at any time to improve its product, without prejudice to the essential characteristics described

in this manual. The Manufacturer is not obliged to add such modifications to machines previously manufactured, already delivered, or under construction.

- ⚠ The appliance can be used by children aged 8 years and above and by persons with reduced physical, sensory, or mental capabilities, or those lacking experience or necessary knowledge, provided they are under supervision or have been given instructions concerning the safe use of the appliance and understand the hazards involved. Children should not play with the appliance. Cleaning and maintenance intended to be carried out by the user should not be done by children without supervision.

Specific warnings for R32

The document only contains some of the safety rules regarding R32 refrigerant. For more comprehensive information, please read the safety data sheet available from the retailer.

- ⚠ In each chapter, specific warnings are included for the operations described within. These warnings should be read before starting any activities.
- ⚠ All precautions regarding the handling of refrigerant must be followed in accordance with current regulations.
- ⚠ The unit uses R32 refrigerant, with a Global Warming Potential (GWP) of 675. Do not release R32 gas into the atmosphere.
- ⚠ The R32 refrigerant gas is mildly flammable and odourless.
- ⚠ Do not place flammable objects (spray cans) within 1 meter of the air discharge.
- ⚠ Avoid proximity to continuously operating ignition sources (open flames, gas appliances, electric stoves, lit cigarettes, etc.).
- ⚠ In case of refrigerant gas leakage, ventilate the area thoroughly and move away. Promptly call the Authorised Service Centre or professionally qualified personnel and do not personally intervene on the appliance.

1.3 Basic safety rules

We would like to remind you that the use of products that use electricity and water involves observing certain basic safety precautions such as:

- ⊖ It is forbidden to touch the appliance with wet or damp body parts.
- ⊖ It is forbidden to carry out any operation before disconnecting the appliance from the power supply by setting the plant master switch to "OFF".

- ⊖ It is forbidden to modify the safety or adjustment devices without the authorisation and instructions of the appliance manufacturer.
- ⊖ It is forbidden to pull, unplug or twist the electrical cables coming out of the appliance, even if it is disconnected from the mains supply.
- ⊖ It is forbidden to introduce objects and substances through the openings provided for the intake and delivery of air.

⊖ It is forbidden to open the access doors to the internal parts of the appliance without first setting the plant master switch to "OFF".

⊖ It is forbidden to dispose of packaging material and leave it within reach of children as it can be a potential hazard.

1.4 Disposal

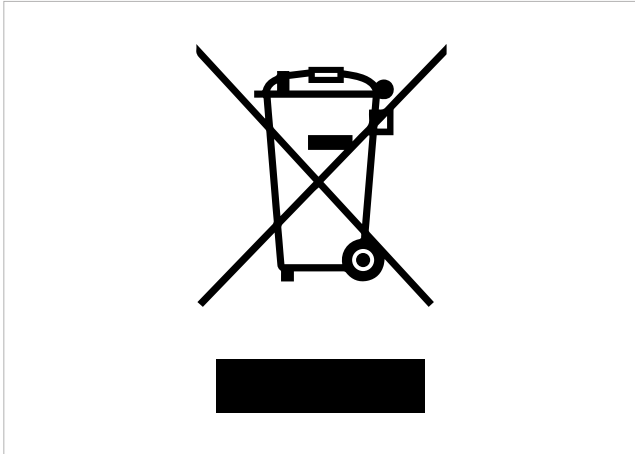

The symbol on the product or packaging indicates that the product should not be treated as normal household waste. Instead, it should be taken to an appropriate collection point for recycling of electrical, electronic, and battery equipment.

Proper disposal of this product avoids harm to humans and the environment and promotes the reuse of valuable raw materials.

For more detailed information about the recycling of this product, contact your local authority, your household waste disposal service, or the shop where you purchased the product.

Illegal disposal of the product by the user involves the application of the administrative sanctions provided for by the regulations in force.

This provision is only valid in the EU Member States.

⚠ Avoid disassembling the appliance yourself.

⚠ **Contact an Authorised Service Centre to disassemble the appliance.**

2. PRODUCT INTRODUCTION

2.1 Identification

The appliance can be identified by the rating plate:

1. Technical rating plate

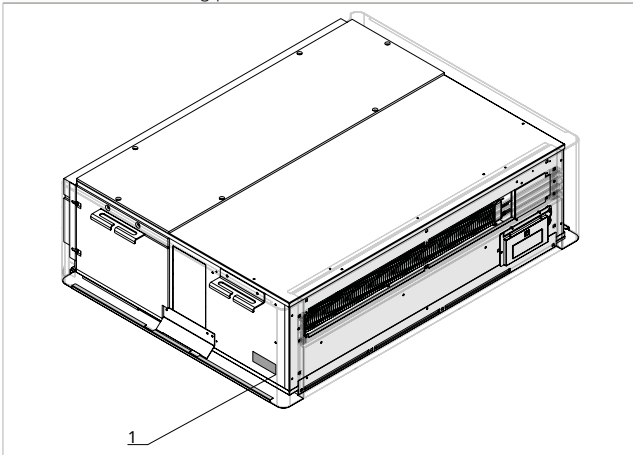

Technical rating plate

This shows the technical and performance specifications of the appliance.

- ⚠ According to EU Regulation No. 517/2014 concerning certain fluorinated greenhouse gases, it is mandatory to indicate the total quantity of refrigerant present in the installed system. This information is available on the technical plate of the unit.
- ⚠ Tampering with, removing or missing identification plates does not allow the product to be reliably identified by its serial number and therefore invalidates the warranty.

2.2 Destination of use

This appliance is an air-to-air conditioning unit designed for applications such as residential buildings, schools, clinics, offices, and any settings where air conditioning is needed without the possibility of installing external units or a supporting thermal plant.

The unit is a heat pump, capable of reversing the refrigeration cycle through a 4-way valve, thus enabling both cooling and heating functions.

The use of a compressor and brushless fans regulated by an inverter allows for high levels of comfort and energy efficiency.

2.3 Description of the appliance

Structure: High-strength structure with a self-supporting frame in sheet metal, materials with high thermal and acoustic insulation characteristics.

Fans: Inverter-regulated brushless fans allow for high levels of comfort and energy efficiency with constant airflow function.

Filter: Flat nylon filter with metal frame.

Refrigeration circuit: copper brazed with high-efficiency BLDC compressor, drier filter, finned coils, electronic expansion valve, and safety devices.

2.4 List of external components

- 1. Air grille
- 2. On-board display

- 3. Lower covering panel
- 4. Side covering panel

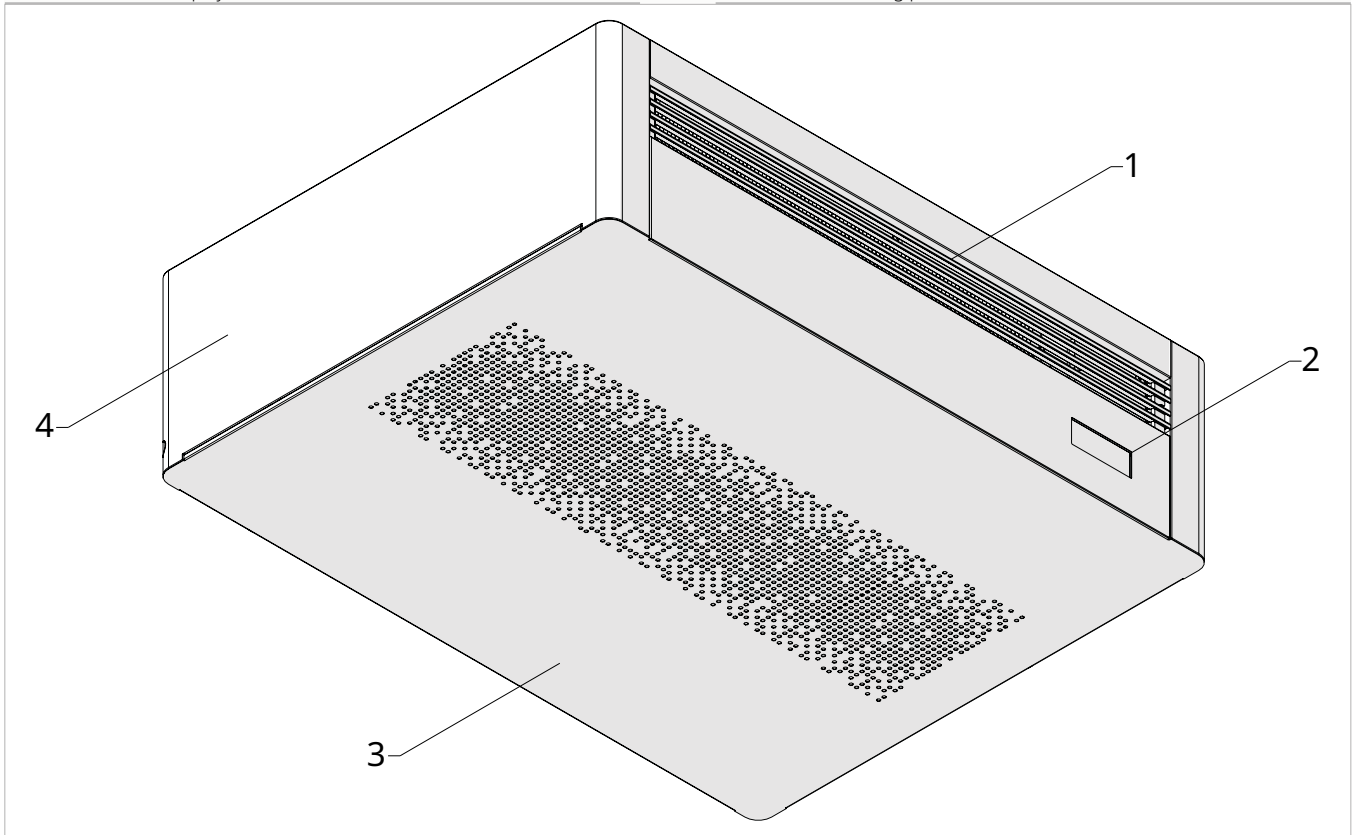

- 1. Electrical connection passage
- 2. Condensate drain

- 3. Outdoor air intake
- 4. Outdoor air exhaust

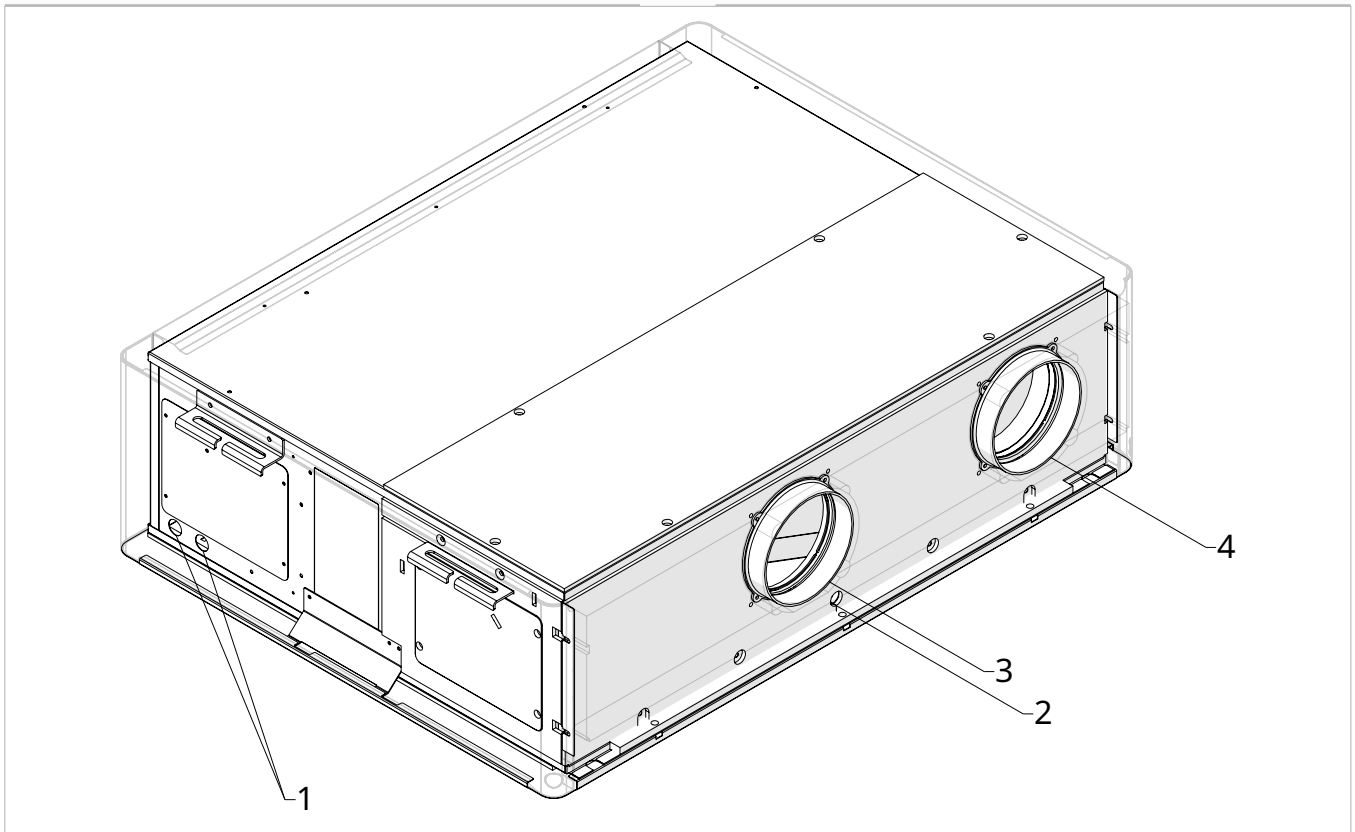

2.5 List of internal components

- | | | | |
|----|-----------------------|----|-------------------|
| 1. | Supply fan | 5. | Compressor |
| 2. | Electrical resistance | 6. | Outdoor side coil |
| 3. | On-board display | 7. | Exhaust fan |
| 4. | Installation bracket | 8. | Indoor side coil |

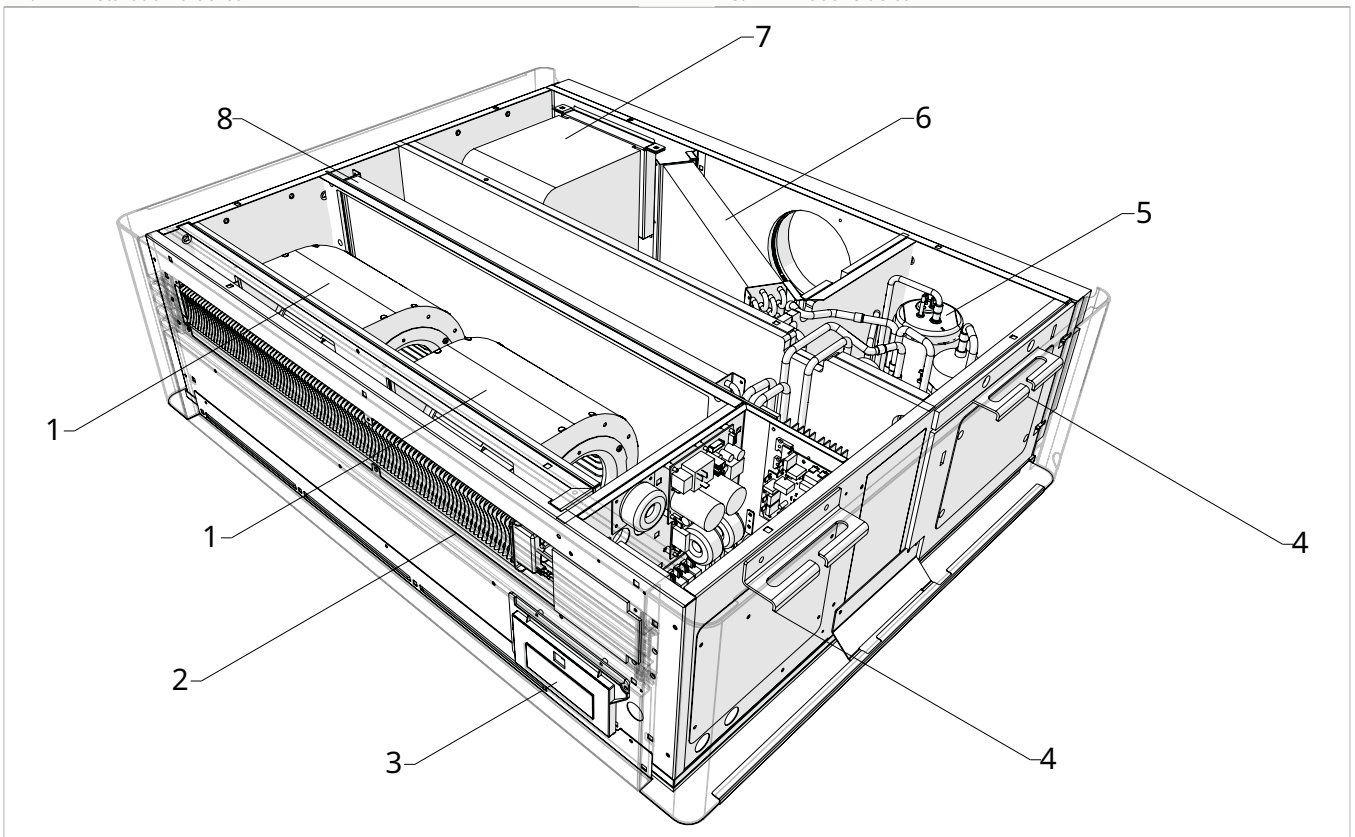

1. Filters

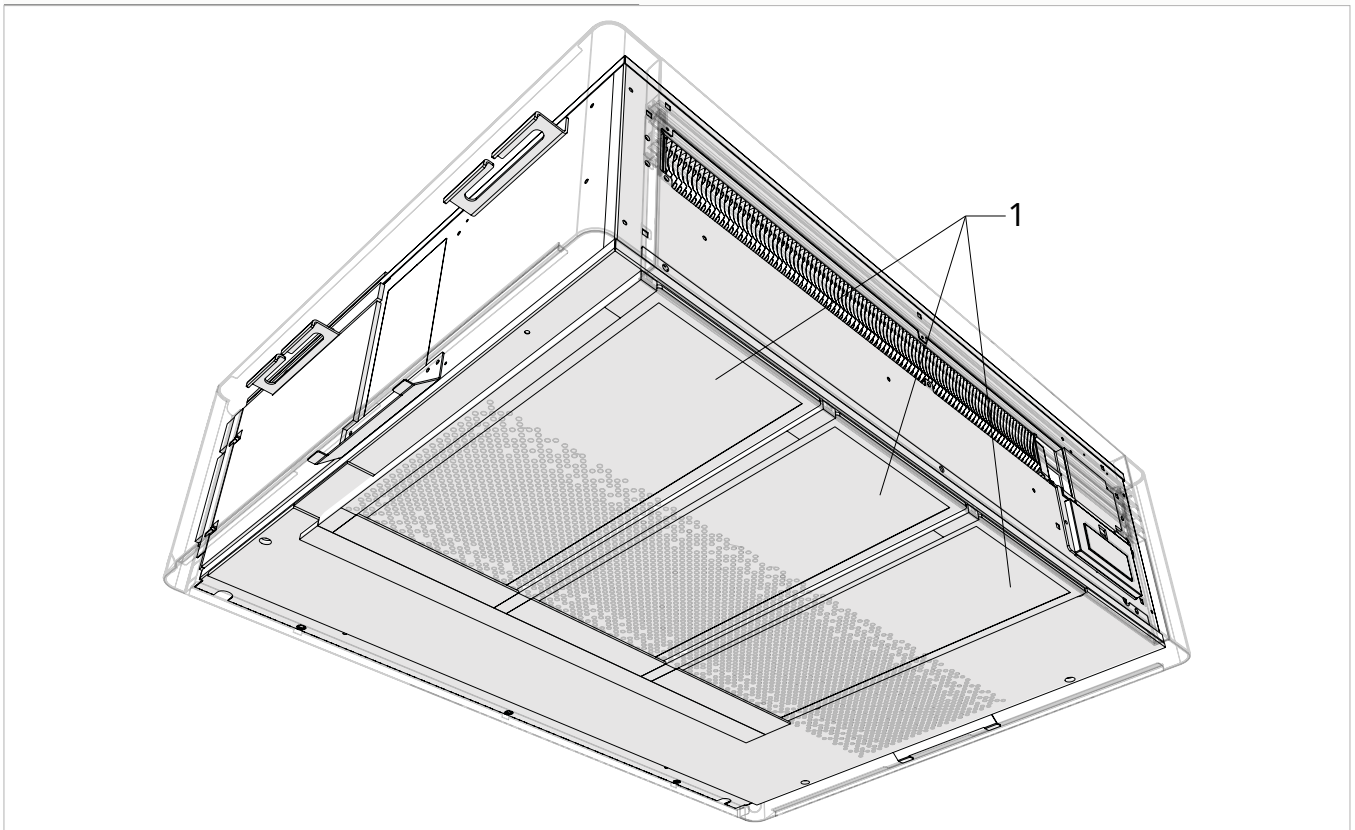

3. INSTALLATION

3.1 Preliminary warnings

- ⚠ **For detailed information on the products, refer to chapter "Technical information" p. 37.**
- ⚠ The installation must be carried out by the installer. There is a risk of water leakage, electric shock or fire if the installation is not performed correctly.
- ⚠ During installation, it is necessary to observe the precautions mentioned in this manual, and on the labels affixed to the inside of the appliances, as well as to take every precaution suggested by common sense and the safety regulations in force at the place of installation.
- ⚠ Using only the supplied installation-specific components is recommended. Use of alternative components could lead to water leakage, electric shock or fire.
- ⚠ Failure to apply the indicated rules may cause malfunctions of the appliance and relieves the Manufacturer

from any warranty and from any damage caused to persons, animals or property.

- ⚠ Air conditioners without an external unit are designed for indoor installation. The only components suitable for outdoor use are the external grilles for air intake and exhaust.

Preliminary warnings for R32

- ⚠ Before working on systems containing flammable refrigerants, it is necessary to perform safety checks to ensure that the risk of combustion is minimised.
- ⚠ The appliance must be protected from accidental impacts to prevent mechanical damage.
- ⚠ Do not pierce or burn.

3.2 Reception

Preliminary warnings

- ⚠ Upon receipt of the package check that it is not damaged, otherwise accept the goods with reservation, producing photographic evidence of any damage.
- ⚠ In the event of damage, notify the shipper by registered mail with return receipt within 3 days of receipt. Presenting photographic documentation, similar information should also be sent by email to the Manufacturer.
- ⚠ No reports of damage will be taken into account later than 3 days after delivery.

- ⚠ The packaging should be transported in a horizontal position without tilting. If it is tilted, please notify the carrier immediately.

Package description

The packaging is made of suitable material and carried out by experienced personnel.

The units are all checked and tested and are delivered complete and in perfect condition.

The appliance is shipped in standard packaging consisting of a cardboard box and a set of polystyrene foam protectors, placed on a wooden pallet and secured with straps.

3.3 Dimensions and weights with packaging

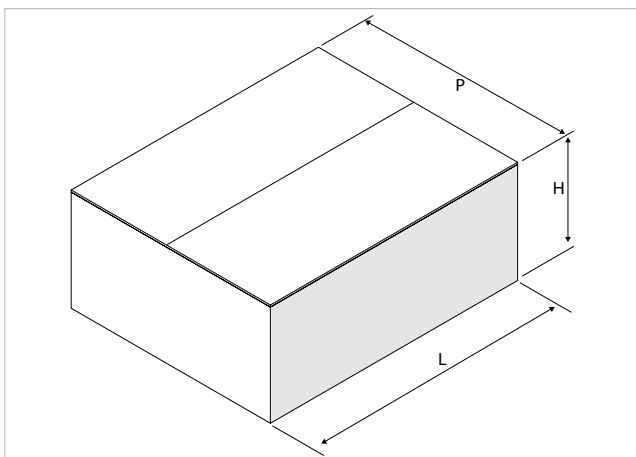

Models	u.m.	2.0 CEILING
Packaging dimensions (1)		
Width	mm	1115
Length	mm	1240
Height	mm	375
Weight	kg	75,0
1. Excluding pallet		

3.4 Handling with packaging

Preliminary warnings

- ⚠ The product should only be handled by qualified personnel, adequately equipped, and using tools suitable for the weight and dimensions of the product.
- ⚠ Before each handling operation, check the lifting capacity of the machinery used in accordance with the indications on the packaging.

Handling

With pallet:

- ▶ use a forklift

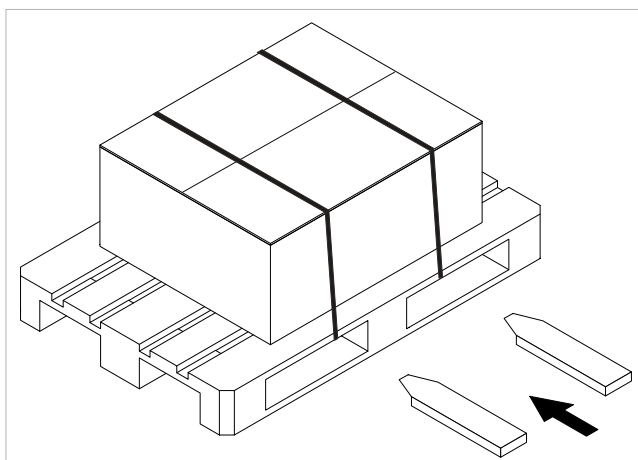

- ⚠ The packaging must be transported in a horizontal position without being tilted.
- ⚠ When the load is lifted from the ground, stay clear of the immediate and surrounding area.
- ⚠ Check the information on the packaging for the amount of stackable packages.
- ⚠ In manual operations, the maximum weight per person required by current legislation must always be observed.

Without pallet:

- ▶ use the handles provided on the packaging

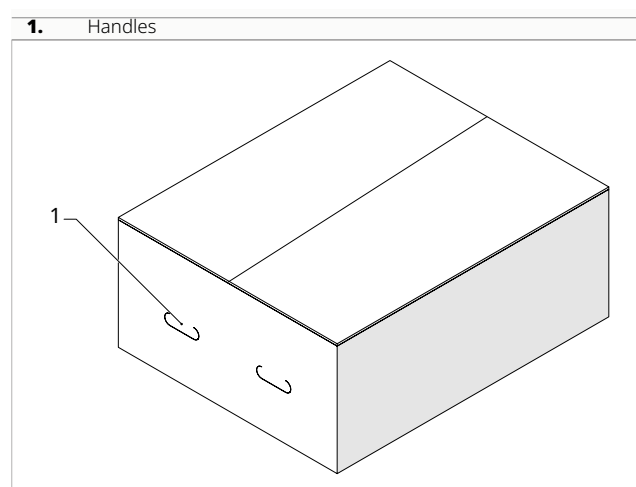

3.5 Storage

Preliminary warnings

- ⚠ Stored in accordance with the applicable national regulations.
- ⚠ Store in a closed environment protected from the weather, off the ground by means of sleepers or pallets

with temperatures not below 0 °C, up to a maximum of 40 °C.

- ⚠ Do not overturn the packaging.
- ⚠ Place the device only in a horizontal position.

3.6 Unpacking

Preliminary warnings

- ⚠ Check that the individual components are present.
- ⚠ Check that no components were damaged during transport.
- ⚠ Dispose of the packaging components following the applicable waste disposal regulations. Check for disposal arrangements with your local authority.
- ⚠ Handle with care.
- ⚠ The appliance must always be handled in a horizontal position.
- ⚠ Check for the presence of refrigerant inside the packaging using an electronic leak detector suitable for the system's refrigerant. If present, it is likely that the re-

frigerant circuit is damaged. In this case, the appliance should not be installed, and it is necessary to contact the Authorised Service Centre.

- ⊖ The packing material (cardboard, staples, plastic bags, etc.) must not be dispersed or abandoned in the surrounding environment and must be kept out of reach of children due to risk of hazard.

Removing the packaging

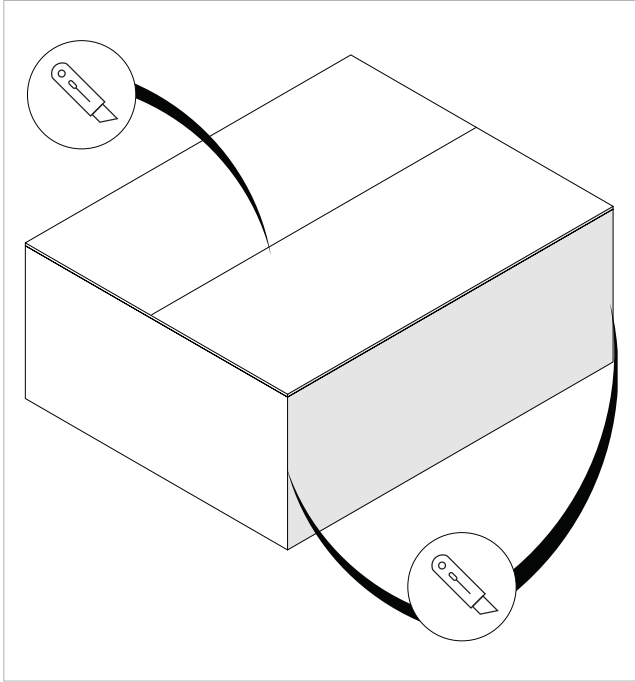

To remove the packaging:

- ▶ use a cutter
- ▶ open the cardboard packaging
- ⓘ To aid removal of the product, also cut the vertical edges.
- ▶ remove the accompanying components
- ▶ remove the polystyrene elements
- ▶ remove the appliance from the box

Accompanying material

They are included with the appliance, inside the packaging:

- 2 paper dimes for drilling
- External grille for air intake
- External grille for air exhaust
- 2 internal flanges
- 2 plastic sheets to roll for the creation of air ducts
- Remote control
- CR2025 3V remote control battery
- Control panel user manual
- Installation manual
- ⚠ Check the presence of the individual components.

3.7 Handling without packaging

Preliminary warnings

- ⚠ The unit must be handled using non-slip gloves.
- ⚠ The product should only be handled by qualified personnel, adequately equipped, and using tools suitable for the weight and dimensions of the product.
- ⚠ Before each handling operation, check the lifting capacity of the machinery used in accordance with the indications on the packaging.
- ⚠ When the load is lifted from the ground, stay clear of the immediate and surrounding area.
- ⚠ Check the information on the packaging for the amount of stackable packages.

- ⚠ In manual operations, the maximum weight per person required by current legislation must always be observed.

Movement methods

- ▶ use a fork lift, scaffolding or other suitable lifting system
- ⚠ The unit can only be moved manually for short trips in exceptional cases. In this case it is necessary to carefully check that the weight of the unit does not exceed what is stipulated by the regulations with respect to the number of persons employed.

3.8 Installation site

The location of the appliance must be determined by the plant engineer or a competent person and must take into account both purely technical requirements and any national/local legislation in force.

The appliance is intended to be installed indoors in a horizontal position fixed to the ceiling.

- ⚠ The installation position must be chosen close to a wall connected to the outside.
- ⚠ The appliance is declared IPX0 protected, therefore not suitable for installation outdoors or in rooms with the presence of water (swimming pool, etc.).

Preliminary warnings

- ⚠ Avoid installing the unit in the vicinity of:

- obstacles or barriers that cause recirculation of the exhaust air
- narrow places where the sound level of the appliance can be enhanced by reverberations or resonances
- environments with the presence of flammable or explosive gases
- very damp environments (laundries, greenhouses, bathrooms with high humidity, etc.) to prevent the formation of condensation on the external panels of the unit
- environments with the presence of flammable or explosive gases or flammable fluids
- solar radiation and proximity to heat sources
- ⚠ **Avoid installing the unit in the vicinity of the sea. Salty atmospheres cause corrosion and oxidation**

of the internal components, compromising the functioning of the unit.

- ⚠ Avoid placing the unit within 1 metre of radio and video equipment.
- ⚠ Do not install above heat sources.
- ⚠ Ensure that:
 - the installation site of the unit must be chosen with the utmost care to guarantee adequate protection from shocks and consequent damage
 - the supporting surface is capable of supporting the weight of the appliance
 - the supporting surface does not affect load-bearing building elements, piping, or power lines
 - the functionality of load-bearing elements is not compromised
 - there are no obstacles to the free circulation of air through the holes (plants, leaves...)
 - the appliance must be installed in a position where it can be easily serviced
 - the safety distances between the units and other appliances or structures are scrupulously respected so that the air entering and leaving the fans is free to circulate
- ⚠ If improperly installed or placed on an unsuitable surface, the unit, if detached from its base, may cause damage to persons or property.
- ⚠ The appliance must not be in a position where the air flow is aimed directly at a person.
- ⚠ Provide the following:
 - a drain nearby for the outflow of condensation
 - a compliant power supply nearby

Preliminary warnings for R32

- ⚠ The appliance must be installed in well-ventilated environments that have a minimum floor area as indicated in the table "Minimum Floor Area" based on the total refrigerant charge of the circuit.
- ⚠ **The refrigerant charge refers to the total amount of refrigerant in the circuit, which includes the factory charge and any additional charge.**
- ⚠ Please refer to the technical rating plate on the associated outdoor unit for the quantity of refrigerant loaded into the unit.
- ⚠ If the appliance is placed in a poorly ventilated area, precautions must be taken to prevent the accumulation of leaked refrigerant, thus avoiding the risk of fire or explosion.
- ⚠ The appliance should be placed in a room where there are no continuously operating open flames (such as a gas appliance in operation) or ignition sources (such as an operating electric heater).
- ⚠ Any ventilation openings must be kept clear of obstacles.
- ⚠ Perform the following checks:
 - Perform safety checks to ensure that the risk of combustion is minimised
 - avoid working in confined spaces
 - delimit the area around the workspace
 - ensure safe working conditions around the area by checking for flammable materials

Minimum floor area

m (kg)	A _{min} (m ²)
1,8	Without limitations
2,0	2,55
2,1	2,81
2,2	3,09
2,3	3,38
2,4	3,68
2,5	3,99
2,6	4,31
2,8	5,00
3,0	5,74
3,4	7,38
3,8	9,22
4,2	11,26
4,6	13,50
5,0	15,96
5,4	18,61
5,8	21,47

2. **M** Refrigerant charge
 3. **A_{min}** Minimum floor area

Types of installation

A External connections flush with the wall

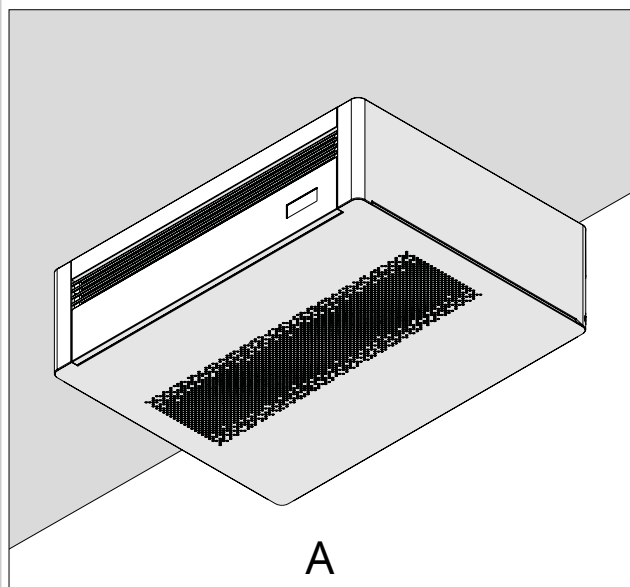

B External ducted connections

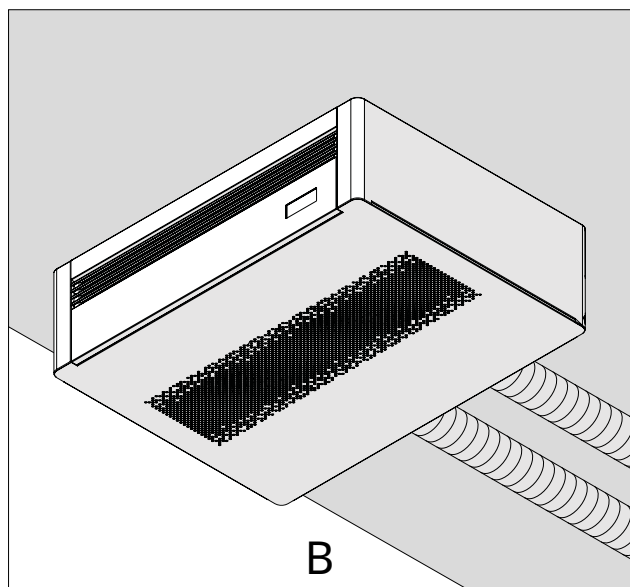

3.9 Minimum installation distances

The clearance zones for the installation and maintenance of the appliance are shown in the figure below. Established spaces are necessary to avoid barriers to airflow and allow for normal cleaning and maintenance.

⚠ Make sure that there is sufficient space to allow the panels to be removed for routine and supplementary maintenance operations.

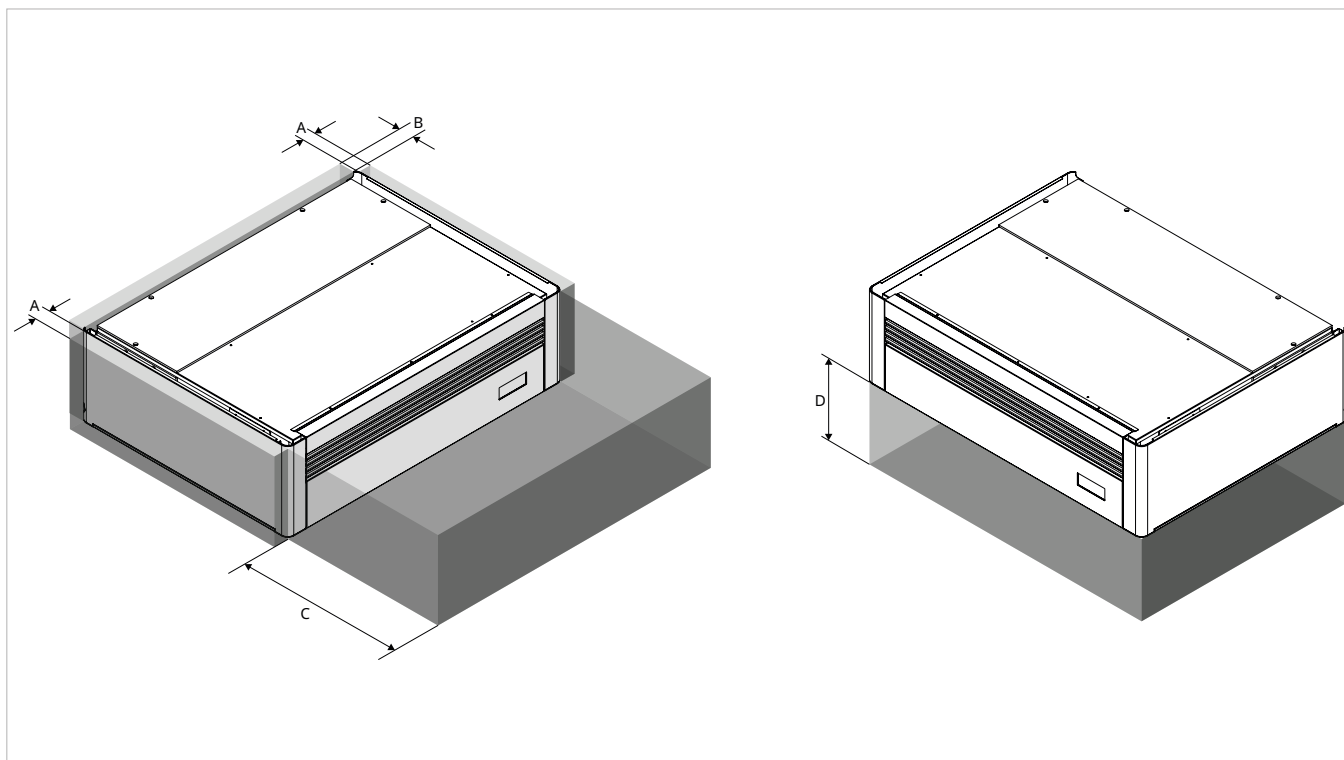

Models	u.m.
Minimum distances	
A	mm
B	mm
C	mm
D	mm

⚠ If the unit is installed without flanges, please place the appliance flush against the wall, dis-

regarding the minimum installation distance 'B' mentioned earlier.

3.10 Positioning

Unit preparation

Before positioning the appliance, it is necessary to remove some of the aesthetic panels and the grille.

Removal of the air grille

1. Position of the grille mounting hole

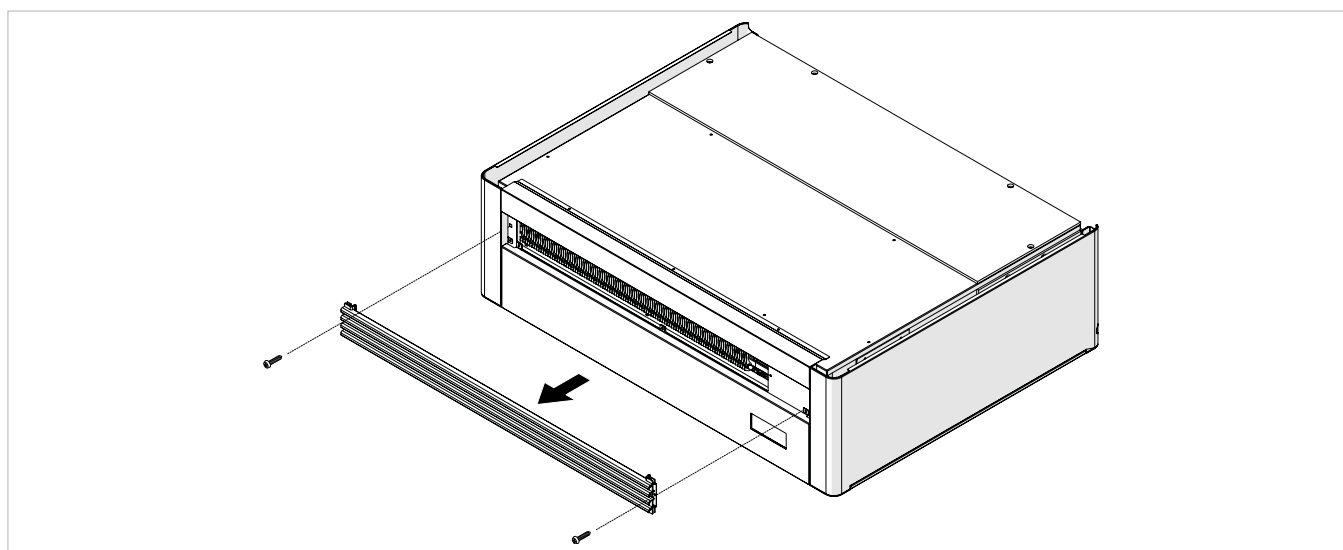
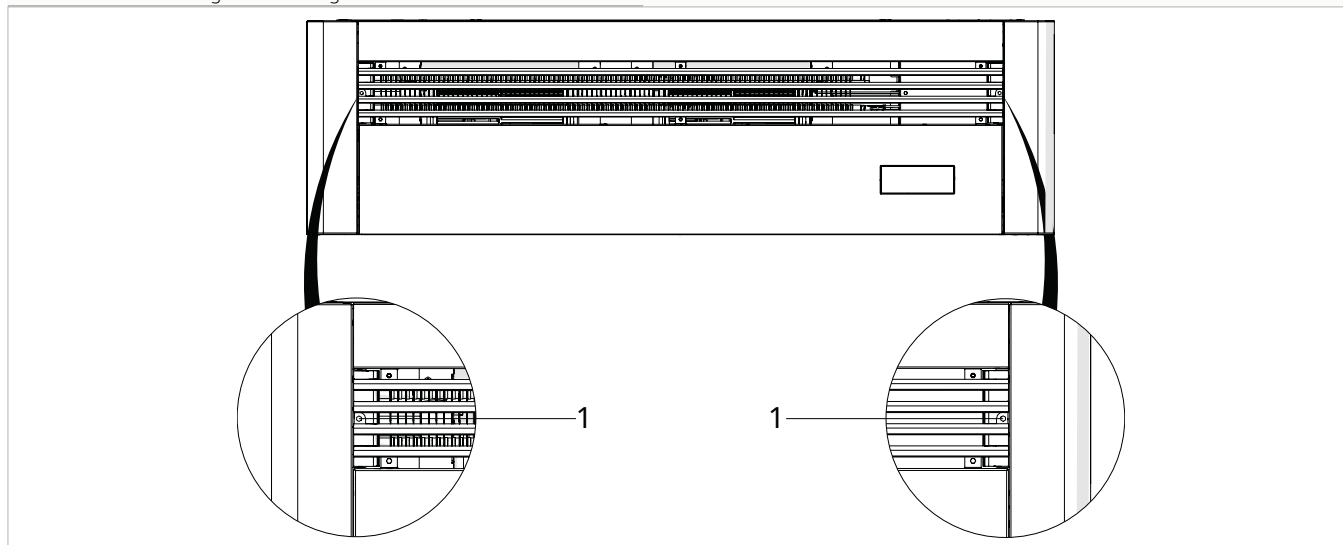

To remove:

- ▶ remove the screws from the grille

- ▶ extract the grille

Removal of the lower front panel

1. Position of the lower front panel mounting hole

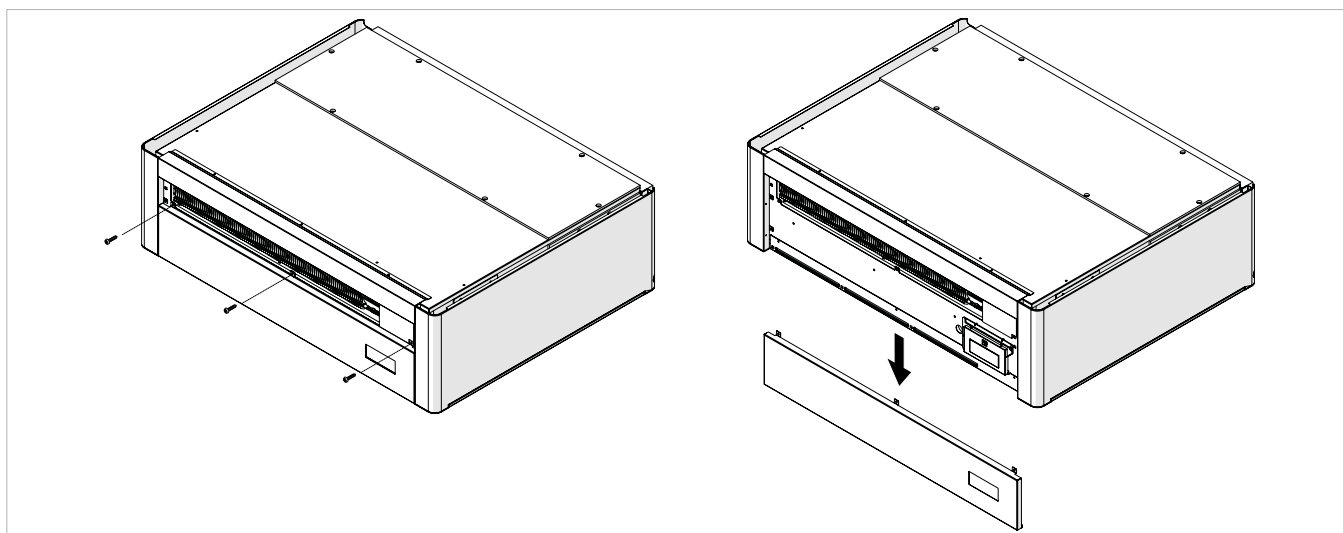
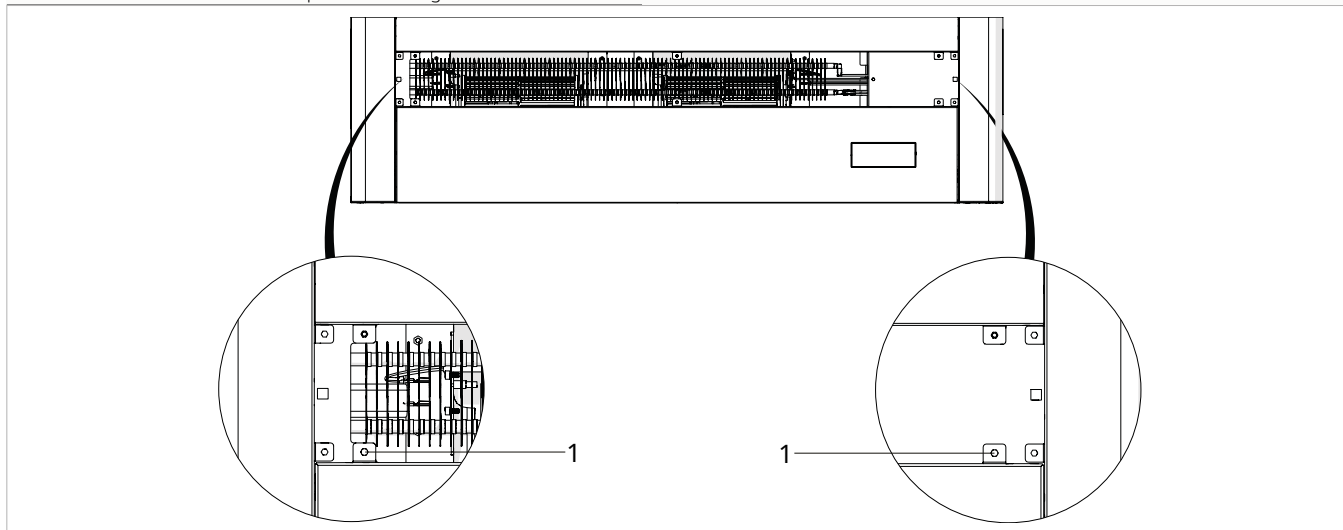

To remove:

- ▶ remove the screws from the panel
- ▶ take out the panel

Removal of the side covering panels

1. Position of the mounting holes for the side panels

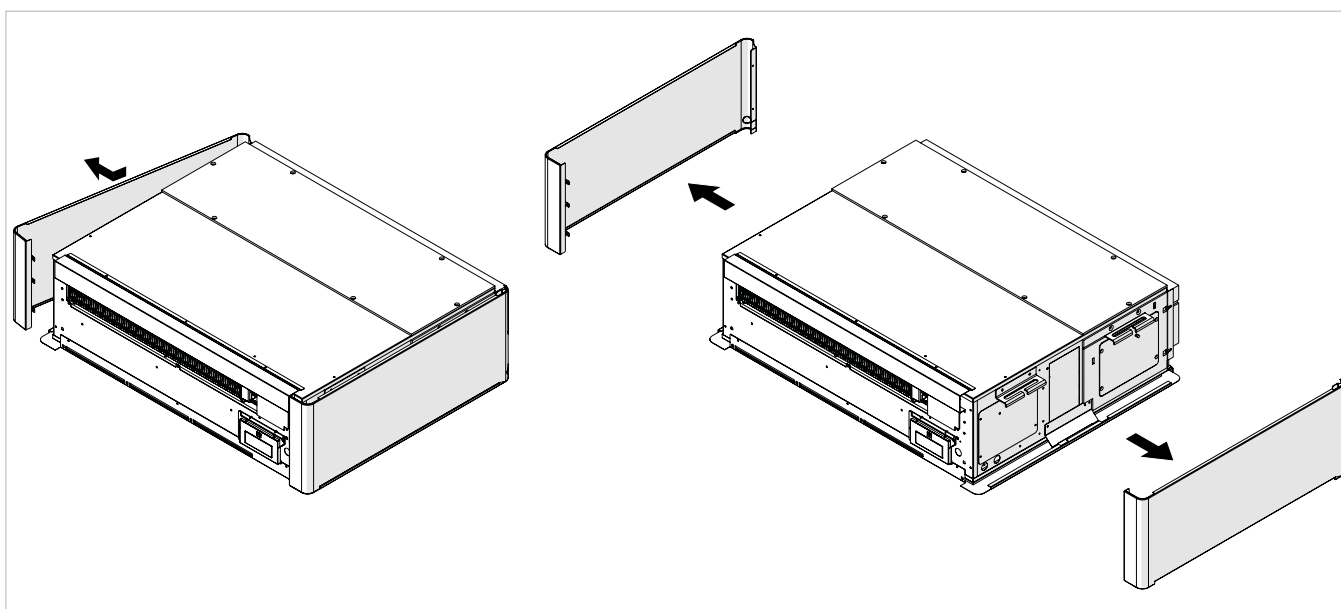
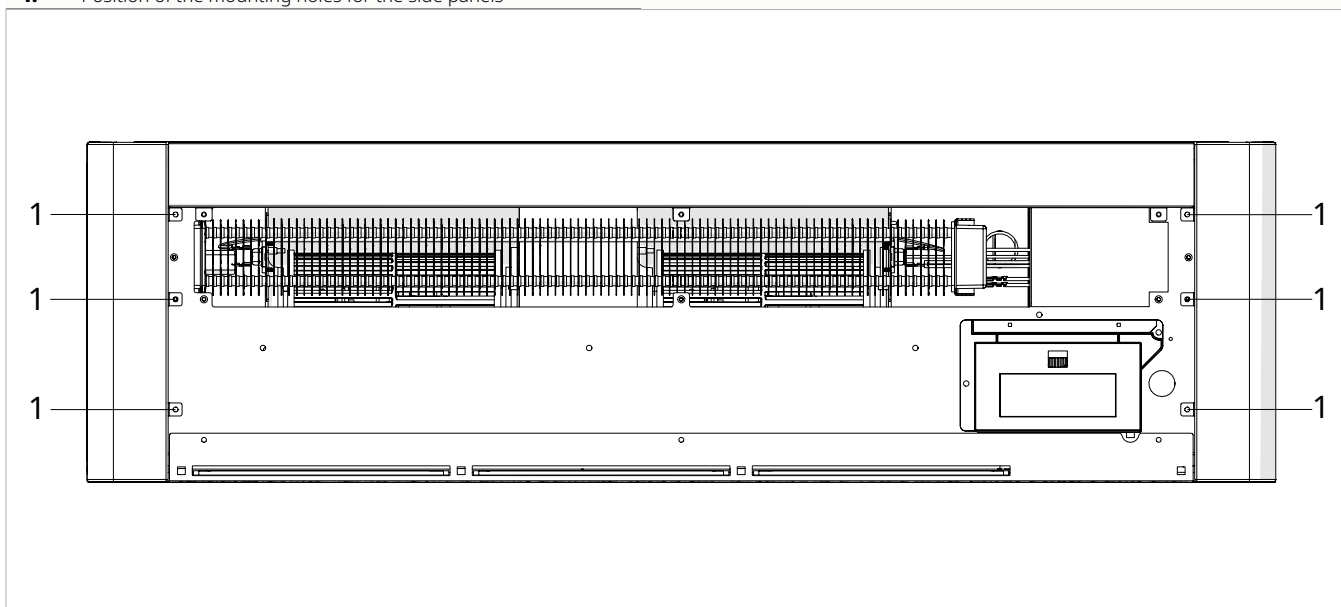

To remove:

- ▶ remove the fixing screws
- ▶ open the panel slightly
- ▶ slide the panel to detach it
- ▶ remove the panel

External connections flush with the wall

Preliminary warnings

The unit must be installed to a secure structure above the unit.

The appliance comes with two paper templates for marking the holes required for installation:

- a template for the passage holes of the air ducts
- a template for the mounting holes of the unit to the ceiling

⚠ Hold the templates in the correct position with adhesive tape.

Drilling the outside wall

- | | |
|----|------------------------------|
| 1. | Condensate drain area |
| 2. | Condensate drain hole Ø20 mm |
| 3. | Outdoor air exhaust |
| 4. | Outdoor air intake |

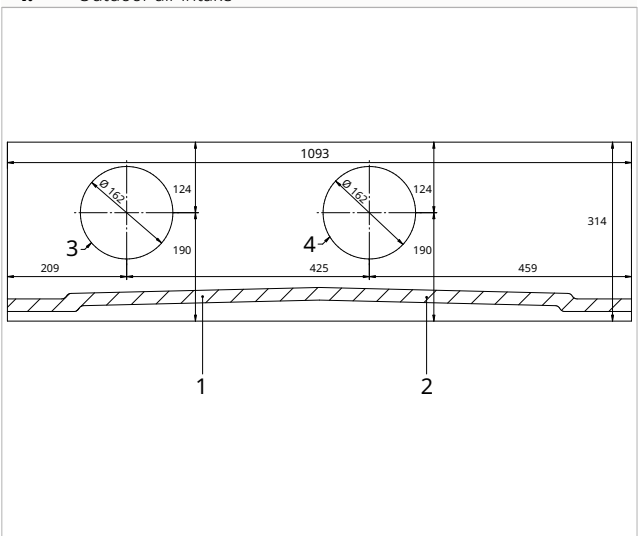

The external wall must be prepared with holes for air ducting.

The appliances are supplied with a paper template for marking the holes required for installation.

To drill the holes:

- ▶ place the paper template
- Ⓜ Secure the template in the correct position with adhesive tape.
- ▶ mark the position of the hole
- ▶ use a drill
- ▶ drill a guide hole
- ▶ use a core drill
- ▶ make a hole through the wall
- ▶ maintain a downward slope towards the outside
- ⚠ The maximum length of the holes is 1 meter.
- ⊖ Curves are prohibited.
- ⚠ To avoid the release of large amounts of dust and debris into the room, you are advised to couple the core drill with a vacuum system.
- ⚠ Proceed with caution near the outside wall to avoid breaking the plaster around the hole.
- ⚠ Take precautions so that the removed material does not hit people and objects below.

Positioning of external dampers

Before proceeding with the installation of the external air dampers, it is necessary to distinguish the one to be positioned on the air intake from the one intended for exhaust. The dampers are identified by the inscription:

IN:external air intake damper

OUT:exhaust damper

⚠ Use exclusively the dampers provided with the unit.

- | | |
|----|----------------------------|
| 1. | Outdoor air exhaust damper |
| 2. | Outdoor air intake damper |

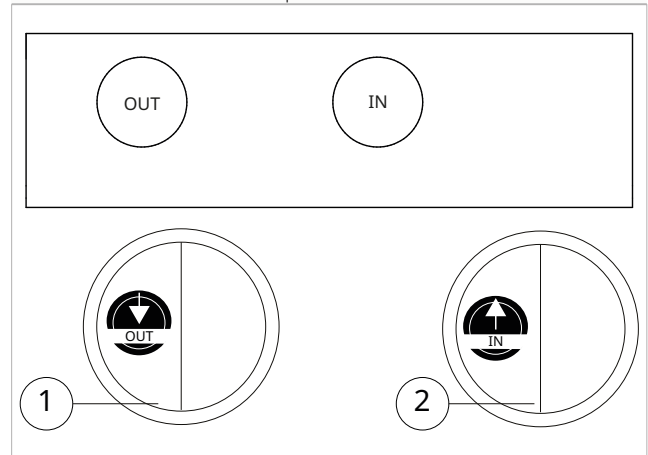

- | | |
|----|---------------|
| 1. | Cord |
| 2. | Counterflange |
| 3. | Spring |
| 4. | Air damper |

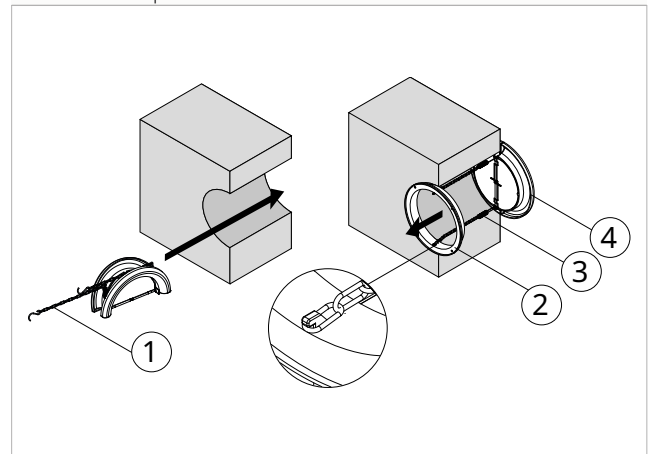

- ▶ fold the damper
- ▶ Insert it into the duct until it emerges on the other side of the wall
- ▶ hold the chains with the other hand to prevent the damper from falling
- ▶ open the damper outside the hole
- ▶ rotate the damper so that the blades are in the vertical position
- ▶ insert the counterflange into the hole towards the interior of the room
- ▶ rotate it so that the hooks are in the vertical position
- ▶ pull the chains to tension the springs

- ▶ hook the chains onto the counterflange
- ▶ cut the excess chain
- ⚠ If painting the dampers, use water-based paints suitable for plastic surfaces to avoid issues with the movement of the blades.
- ⚠ Using thick and sticky paints such as enamels is prohibited.

Positioning of the ductwork

1. Plastic sheet for ductwork

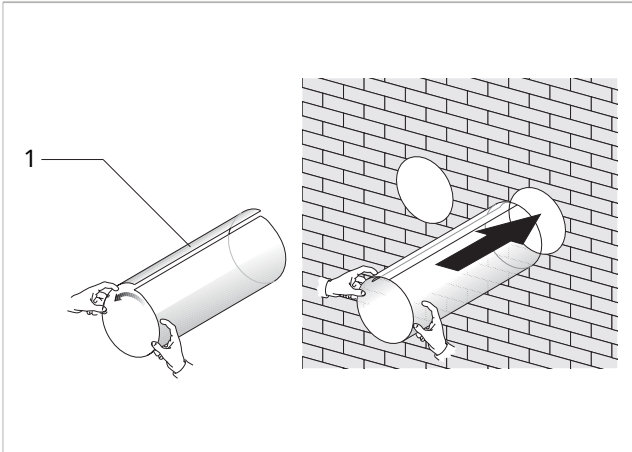

- ▶ measure the depth of the holes drilled in the wall
- ▶ subtract 5 mm from the measured dimension
- ▶ cut the plastic sheets provided to fit the measurement
- ▶ roll up the plastic sheet
- ▶ insert the rolled-up sheet into the hole
- ▶ position so that the edge is 2 mm inside the hole from both sides

Positioning the unit

- | | |
|-----------|---------------------------|
| A | Front side of unit |
| B | Rear side of unit |
| 1. | Eyelets for Ø 8 mm dowels |
| 2. | Rear edge |
| 3. | Insulation |

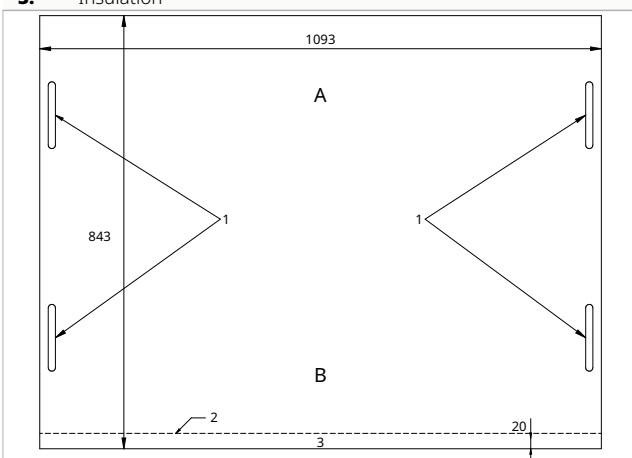

- ▶ use the paper template
- ⚠ Check the correct orientation of the unit.
- ▶ mark the position of the fixing holes

- | | |
|-----------|----------------|
| 1. | Anti-vibration |
| 2. | Washer |
| 3. | Nut |

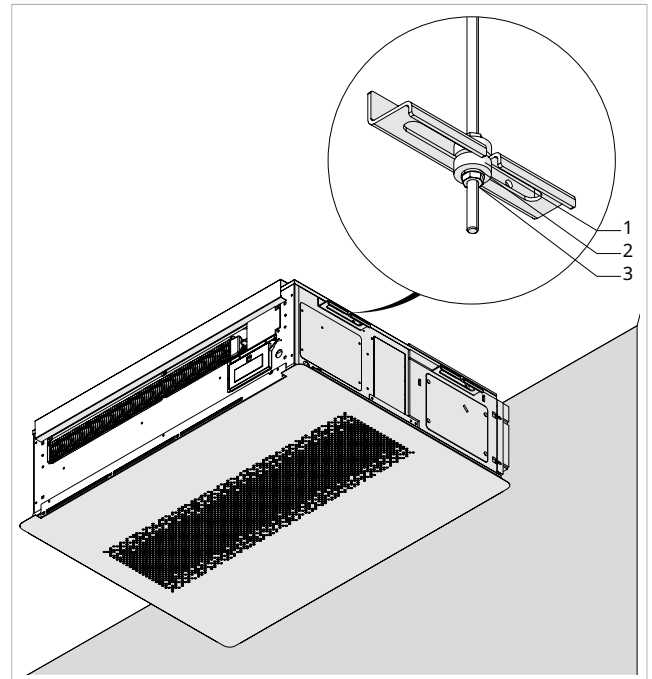

- ▶ use fixing systems appropriate for the type of supporting surface and the weight of the unit
- ▶ push the unit towards the outer wall to create a seal on the air ducts
- ▶ secure the unit to the fixing system
- ▶ reposition the aesthetics and the grille (see paragraph "Unit preparation" p. 15)
- ⚠ Check the horizontal alignment of the installation using a bubble level.
- ⚠ keep the unit detached from the ceiling by at least 10 mm.
- ⚠ do not mount the unit with the sides in direct contact with the walls to avoid noise and vibrations.

Ducted external connections

Preliminary warnings

The unit must be installed to a secure structure above the unit.

- ⚠ Make sure to have installed the supplied nipples before proceeding with the installation of the unit.
- ⚠ Check that:
 - the surface supports the weight of the appliance
 - the surface does not affect piping or power lines
 - the functionality of load-bearing elements is not compromised

Drilling the outside wall

The external wall must be prepared with holes for air ducting.

To drill the holes:

- ▶ mark the position of the hole
- ▶ use a drill
- ▶ drill a guide hole
- ▶ use a core drill
- ▶ make a hole through the wall
- ▶ maintain a downward slope towards the outside
- ⚠ To avoid the release of large amounts of dust and debris into the room, you are advised to couple the core drill with a vacuum system.
- ⚠ Proceed with caution near the outside wall to avoid breaking the plaster around the hole.
- ⚠ Take precautions so that the removed material does not hit people and objects below.

Flange positioning

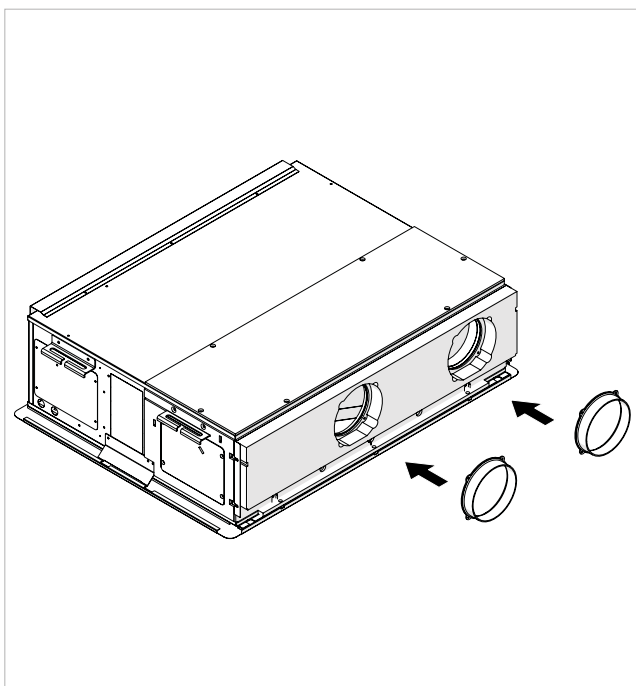

To install the flanges:

- ▶ Install the supplied flanges on the rear side of the unit
- ▶ use the provided screws

Positioning the unit

- | | |
|----|----------------------|
| 1. | Installation bracket |
| 2. | Outdoor side |
| 3. | Indoor side |

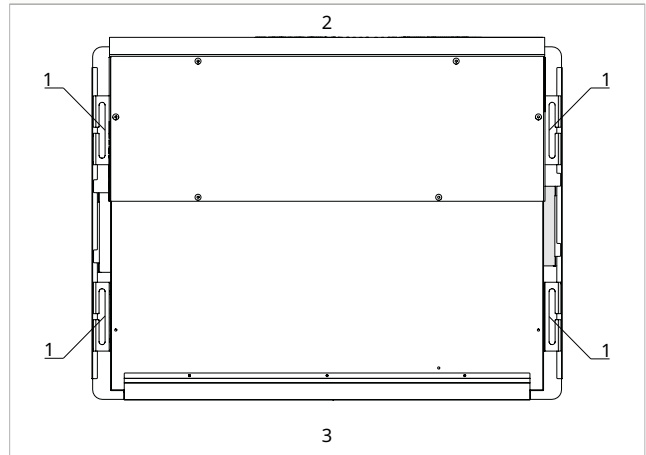

- ⚠ Check the correct orientation of the unit.
- ▶ mark the position of the fixing holes

- | | |
|----|----------------|
| 1. | Anti-vibration |
| 2. | Washer |
| 3. | Nut |

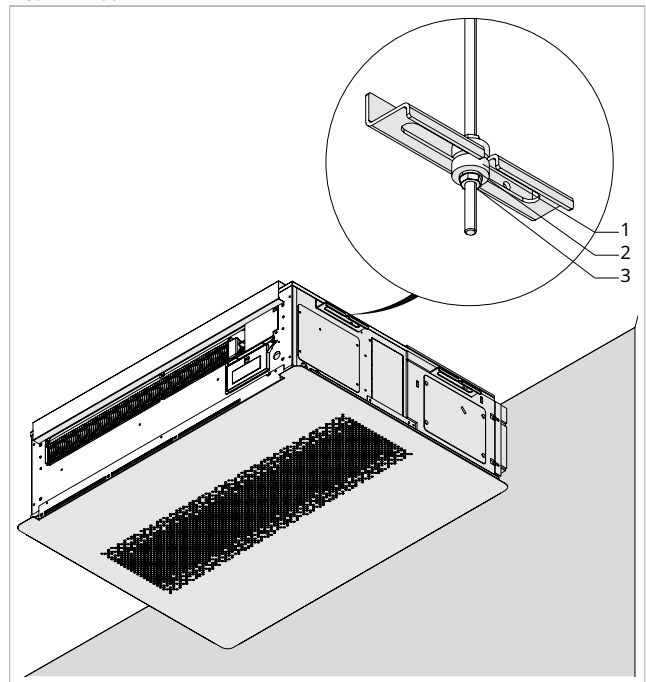

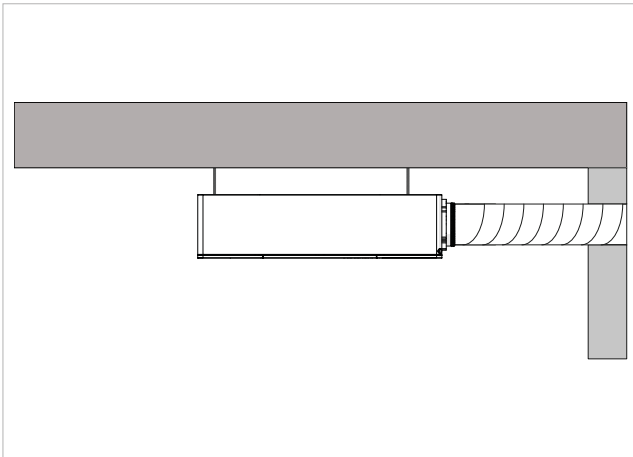

- ▶ use fixing systems appropriate for the type of supporting surface and the weight of the unit
- ▶ secure the unit to the fixing system
- ⚠ Check the horizontal alignment of the installation using a bubble level.

Aeraulic connections

Preliminary warnings

- ⚠ The sizing of ducting and supply and extract grilles must be carried out by a professionally qualified person.
- ⚠ To prevent the transmission of any vibrations of the machine into the room, an anti-vibration joint should be placed between the fan outlets and the ducts.
- ⚠ The connecting pipes must be of a suitable diameter and supported so that their weight does not put strain on the appliance.

Connections

1. Outdoor air intake
2. Outdoor air exhaust

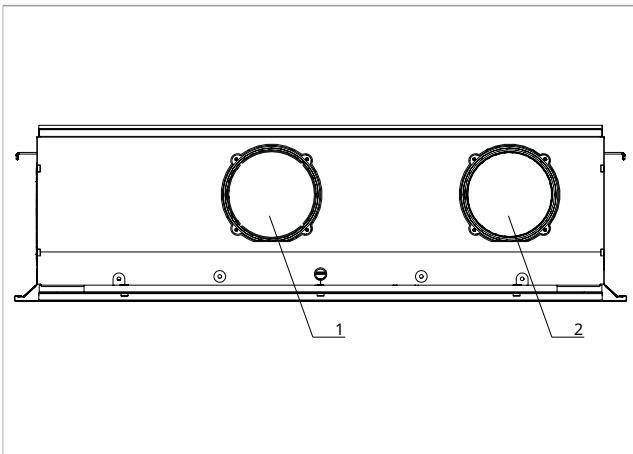

		2.0
Models	u.m.	2.0 CEILING
Connections		
External air intake connection	mm	160
External air exhaust connection	mm	160

Circular connections

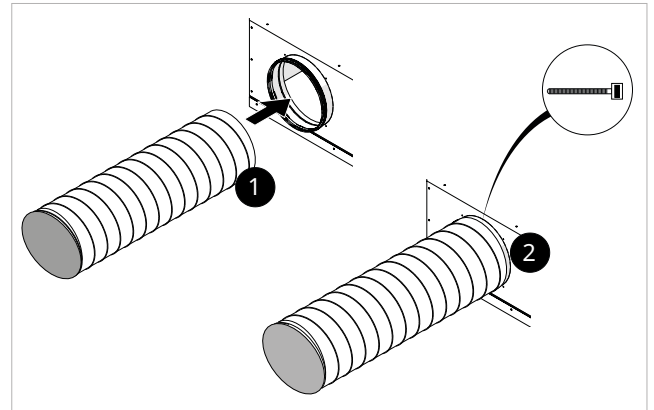

- ▶ position the ducts on the connections provided on the appliance
- ▶ use a metal clamp or duct fixing collar
- ▶ fix the ducts on the attachments
- ⚠ Use ducts lined with anti-condensation material of a suitable thickness.

3.11 Condensate drainage provision

Due to the thermodynamic heat recovery system of the dehumidification coils, the humidity in the air condenses inside the unit.

This unit comes with a condensate collection tray that must be directed to a suitable drainage location.

The dimensions and positioning of the exhaust are outlined below.

Preliminary warnings

- ⚠ If the drainage line runs into a container (tank or other) it must be ensured that the container itself is hermetically sealed and most importantly it must be ensured that the drainage pipe is not immersed in water.
- ⚠ The hole for the condensate pipe must always have an downwards slope.

- ⚠ The precise position where the tube inlet should be placed concerning the machine is specified on the drilling template.
- ⚠ Pay attention in this case to ensure that the expelled water does not cause any damage or inconvenience to objects or people. During the winter period, this water could lead to ice formations outside.
- ⚠ When connecting the condensate drain, take care not to crush the rubber pipe.

Attachment position

The size and the position of the condensate drain connection are shown below.

1. Condensate drain Ø18 mm

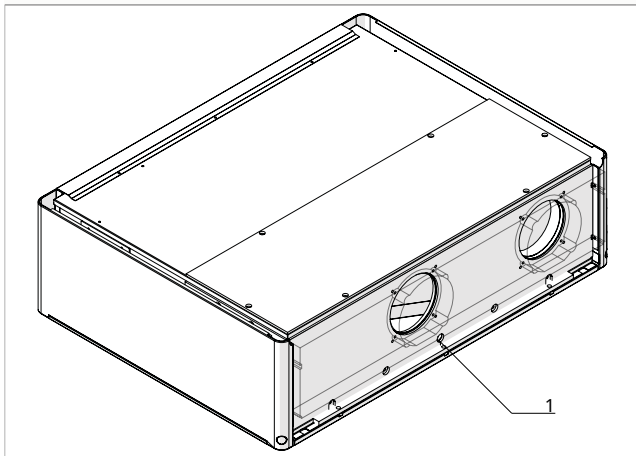

Connections

- ⓘ **If the pipe stub is not long enough:**
 - ▶ remove the plug from the discharge connection
 - ▶ connect the drainage tube
 - ▶ direct it towards a suitable discharge location
 - ▶ maintain a minimum slope of 2% towards the drainage point
 - ▶ insulate junction points
- ⚠ **It is mandatory to install an adequate siphon on the condensate drainage pipe to prevent the negative pressure generated by the fans from obstructing the proper flow of condensate, which could lead to spillage inside the premises.**
 - ⚠ Use plastic drainage pipes.
 - ⚠ Avoid metal pipes.
 - ⚠ Make sure all joints are sealed to prevent leakage of water.
 - ⚠ The condensate drain pipes must be insulated both for sections inside and outside the buildings to prevent condensation on the surface and/or freezing issues.
 - ⚠ If necessary, the condensate collection tray can be emptied through a safety drain located on the base of the appliance; refer to the "Extraordinary Maintenance" chapter.

In case of using a tank for condensate collection:

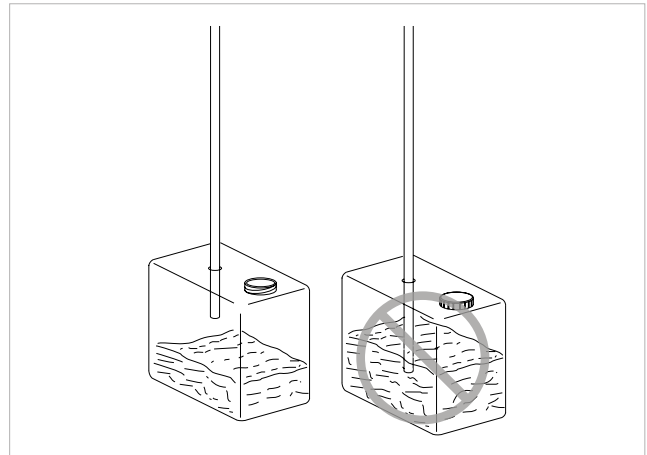

- ⚠ Avoid airtight sealing of the container.
- ⚠ Prevent the end of the drainage tube from being below the water level.

If connected to the sewer system:

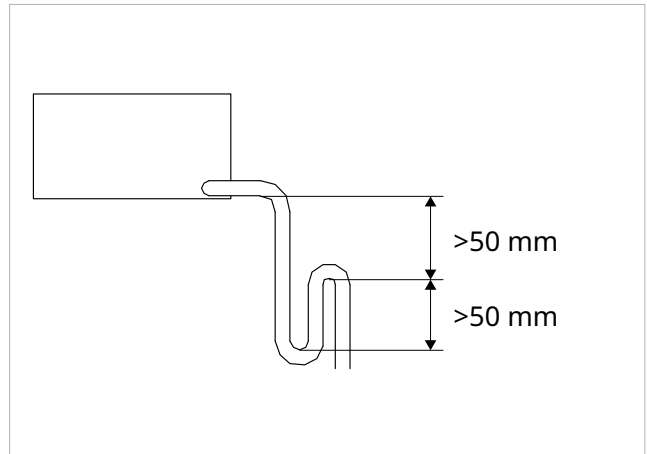

- ⚠ **It is mandatory to install an adequate siphon on the condensate drainage pipe to prevent the negative pressure generated by the fans from obstructing the proper flow of condensate, which could lead to spillage inside the premises.**
- ⚠ The drainage system must include a suitable siphon to prevent unwanted air from entering the vacuum system. The siphon also prevents the entry of odours or insects.
- ⚠ The siphon must be fitted with a plug at the bottom or must in any case permit quick dismantling for cleaning.

If using free drainage:

- ⚠ In the absence of collection, condensate accumulates on the support surface. In case of temperatures below freezing, it may freeze and pose a danger: provide appropriate barriers to prevent people from approaching the area.

3.12 Electrical connections

Preliminary warnings

- ⚠ Before connecting the unit, make sure that:
 - the voltage and frequency values of the power supply comply with the specifications on the nameplate data of the appliance
 - the power supply line must have an effective grounding connection and be correctly sized for the maximum absorption of the unit
 - the socket used is compatible with the supplied plug
- ⚠ The appliance must be connected to the electrical power supply at 230V/50Hz through a single-pole switch with a minimum contact opening distance of at least 3 mm, or by a device that allows the complete disconnection of the appliance under category III surge conditions.
- ⚠ However, it is necessary to verify that the electrical supply is equipped with adequate protections against overloads and/or short circuits (it is recommended to use a delayed fuse of type 10 A or other devices with equivalent functions for the exclusive use of the unit).
- ⚠ To prevent the risk of electric shock, it is essential to disconnect the main switch before making electrical connections and performing any maintenance operations on the appliances.
- ⚠ Make only the necessary electrical connections by consulting the wiring diagram in this manual.
- ⚠ Verify that the electrical components chosen for the installation (main switch, circuit breakers, cable size, and terminals) are suitable for the electrical power of the installed unit and take into account the starting currents of the compressor as well as the maximum achievable load. The relevant data is indicated on the attached wiring diagram and on the unit's nameplate.
- ⚠ Avoid running electrical cables in direct contact with pipes or components inside the unit.
- ⚠ Access to the electrical panel is required only in case of cable replacement or when using the presence contact.

Preliminary warnings for R32

- ⚠ The R32 refrigerant gas is mildly flammable and odourless.
- ⚠ All precautions regarding the handling of refrigerant must be followed in accordance with current regulations.
- ⚠ Avoid proximity to continuously operating ignition sources (open flames, gas appliances, electric stoves, lit cigarettes, etc.).
- ⊘ Smoking is prohibited near the appliance.
- ⊘ The use of mobile phones is prohibited near the appliance.
- ⚠ Perform the following checks:
 - Perform safety checks to ensure that the risk of combustion is minimised
 - avoid working in confined spaces
 - delimit the area around the workspace
 - ensure safe working conditions around the area by checking for flammable materials

Access to the electrical panel

- ⚠ Access to the electrical panel is only permitted to qualified personnel.
- ⚠ Before performing any intervention, ensure that the unit is not powered.

To access the connections:

- ▶ if installed, remove the side aesthetic panels (see chapter "Unit preparation" p. 15)
- ▶ unscrew the screws of the electrical panel cover
- ▶ remove the cover

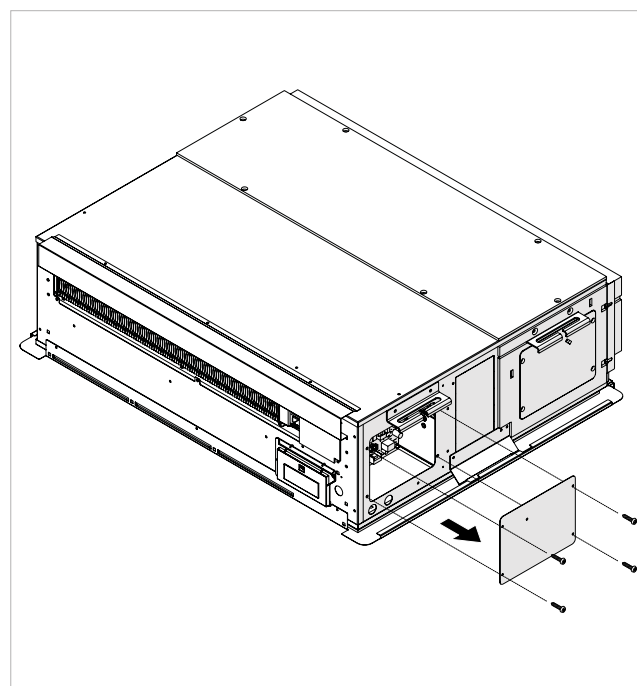

Connections

The unit comes with all electrical connections pre-set and with a Schuko plug for connection to the electrical network. The plug is designed to exit from the rear of the unit through a Ø16 hole; In case it is not possible to connect the plug from the rear, it is possible to route the cable through the right side panel using the pre-punched hole.

- ⚠ In case of damage to the power cable, contact the Authorised Service Centre or qualified personnel for replacement.
- ⊘ It is prohibited to personally replace damaged cables.

1. POWER SUPPLY: the unit comes with a plug, and the power supply is connected to the terminals N, L, PE

2. CP - REMOTE ON-OFF: involves an external connection to enable the unit with a presence or window contact. It comes as standard with a jumper

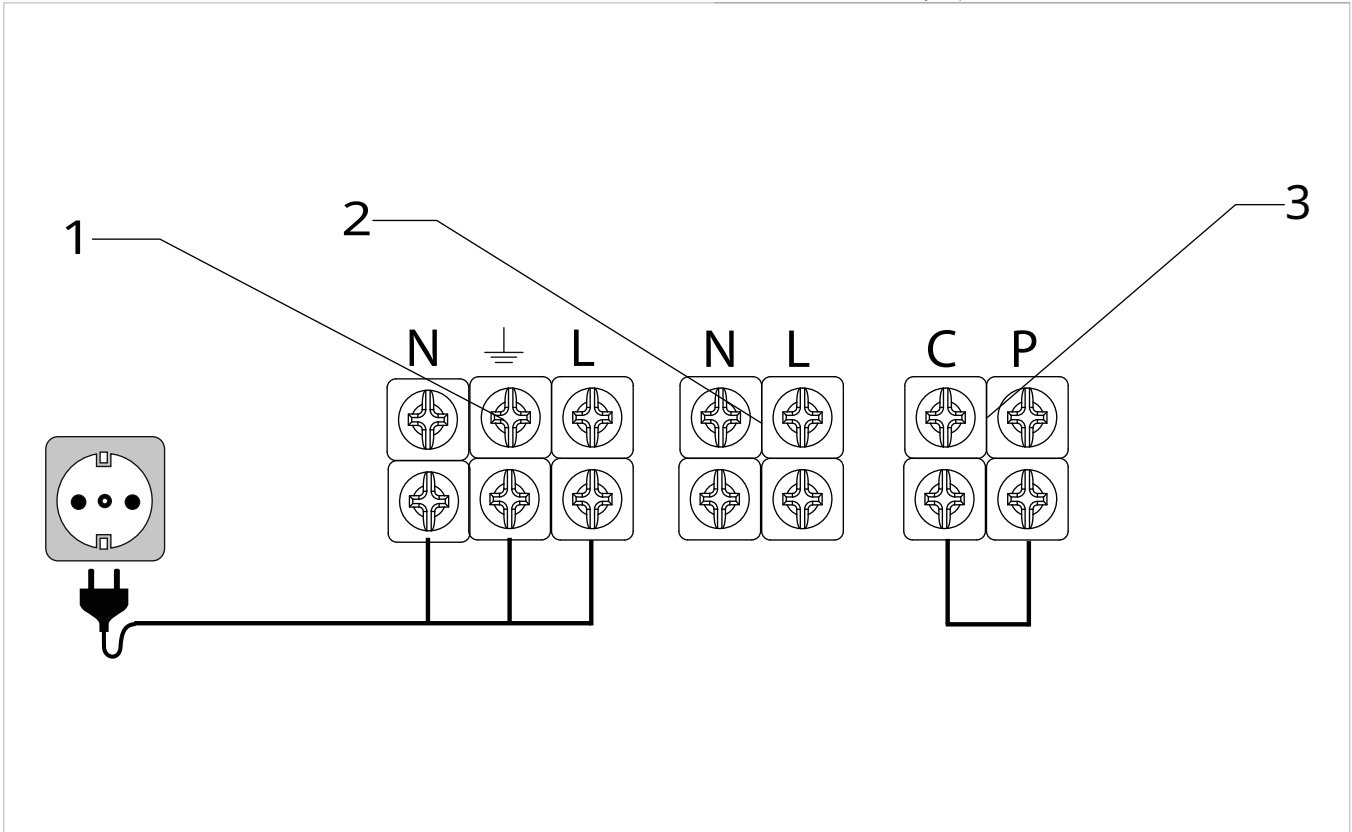

Remote control

⚠ For the remote control, exclusively use CR2025 3V dry lithium batteries (provided).

ⓘ **Used batteries must be disposed of through the designated collection points provided by local authorities for this type of waste.**

To insert the battery:

- ▶ open the dedicated snap-in cover on the lower part of the remote control
- ▶ insert the battery with the + side down
- ▶ close the cover

- 1.** Snap-in cover
- 2.** Battery

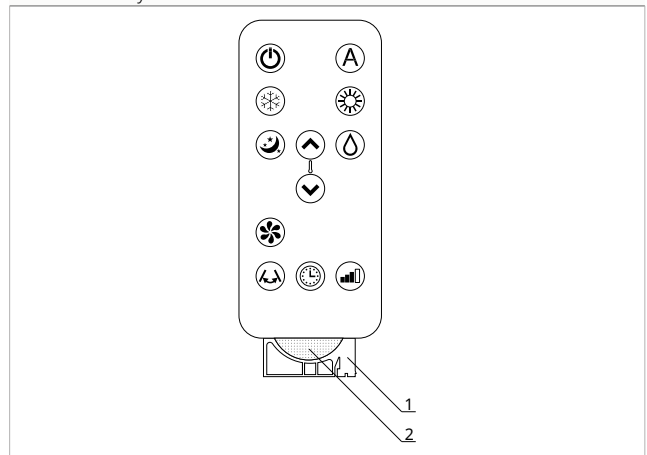

Wiring diagram

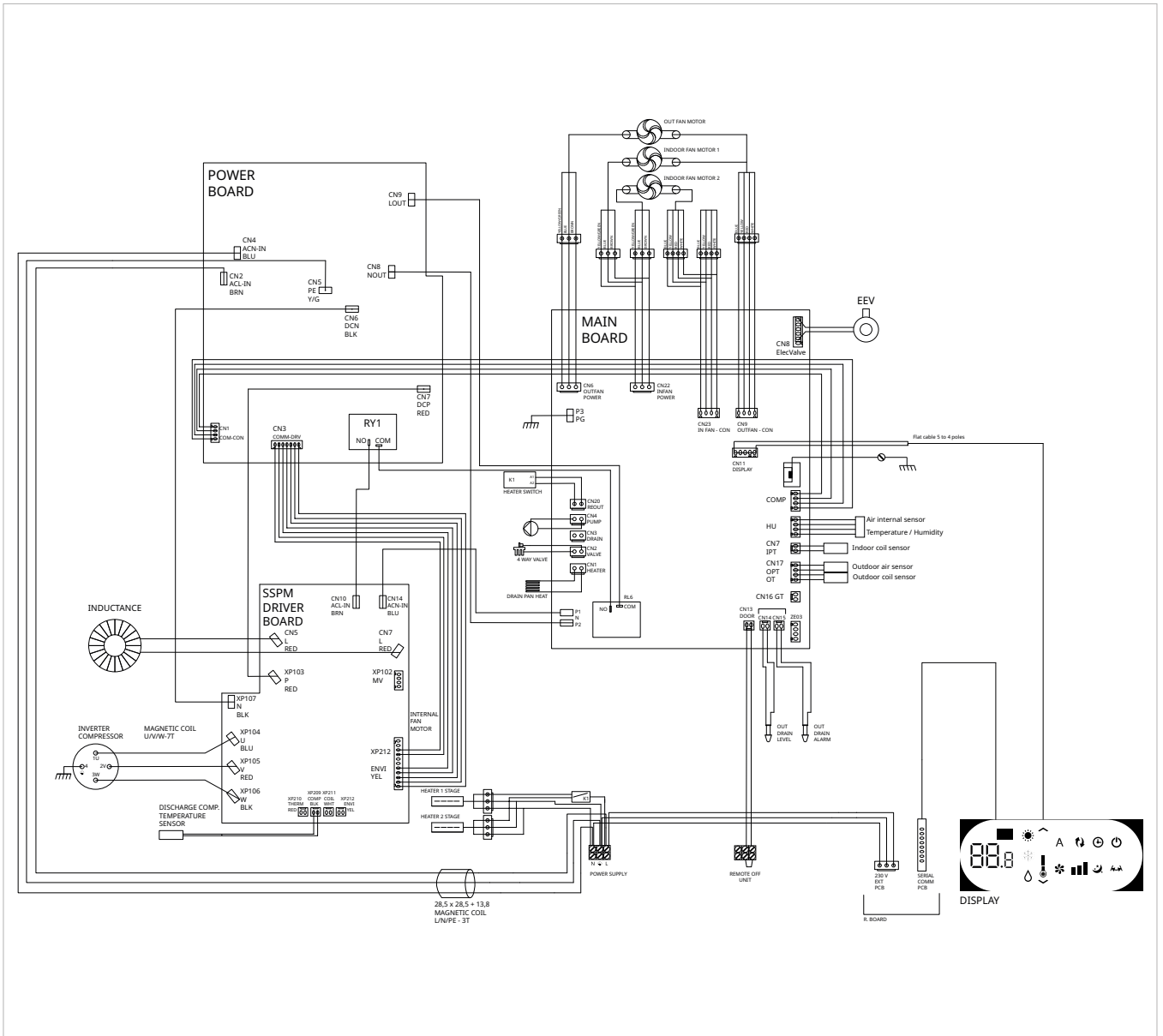

4. THE ON-BOARD DISPLAY AND THE REMOTE CONTROL

4.1 Interface

Remote control



Related keys and functions

- Increases the set temperature
- Decreases the set temperature
- Allows you to activate or put the appliance in stand-by
- Automatic function
- Allows the function in cooling mode only
- Function in dehumidification mode only.
- Allows the function in ventilation mode only
- Allows the function in heating mode only
- Nocturnal wellness key
- Allows control of the ventilation speed
- Allows you to set the timer function

General switch-on

To be able to control the appliance using the remote control or the touch display:

- ▶ insert the power plug of the appliance into the power outlet of the installation or turn on the main switch provided on the power line

Once the operation is performed, through pressing the symbols on the touch screen display or using the remote

control, it will be possible to manage the operation of the system.

Correct use of the remote control:

- Point the front part of the remote control towards the unit's display. The reception of the command will be confirmed by a sound and its corresponding display on the screen
- The maximum distance at which the reception of commands can occur is approximately 8 meters.

To activate the device

- ▶ press and hold the button
 - The display switches on*
 - The set point is shown on the three digits of display*

The control system of the device has a memory, so all the settings will not be lost in case of power outage or shutdown, except for the ventilation. The button in question is used to activate and deactivate the device for short periods.

In case of prolonged shutdown of the device, it should be deactivated by switching off the main power switch or unplugging it from the power outlet.

Description

The unit is controlled through the built-in Wi-Fi panel and the provided infrared remote control.

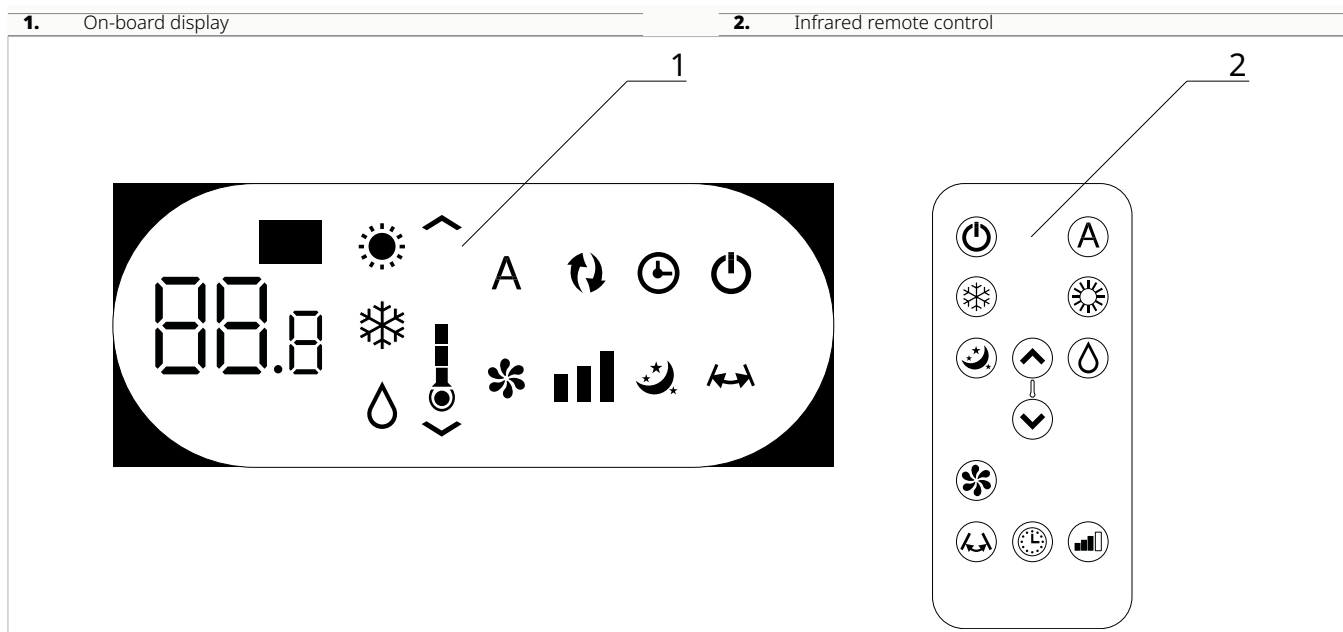

The onboard display allows you to:

- view the operating status
- view any alarms
- select the different functions by pressing the various symbols

The remote control allows you to:

- select the different functions by pressing the various symbols
- ⚠ The supplied remote control has been designed to provide maximum robustness and exceptional functionality. Handle with care.
- ⚠ Do not expose the remote control to rain or liquids.
- ⚠ Do not expose the remote control to the sun rays.
- ⚠ Handle with care, avoiding strong impacts or dropping it onto hard surfaces.
- ⚠ Do not place any obstacles between the remote control and the appliance during use.
- ⚠ In case other devices with remote controls (TV, radio, stereo systems, etc.) are used in the same environment, some interference may occur.
- ⚠ Electronic and fluorescent lamps can interfere with the communication between the remote control and the device.
- ⚠ Remove the battery if the remote control is not going to be used for an extended period of time.

Display

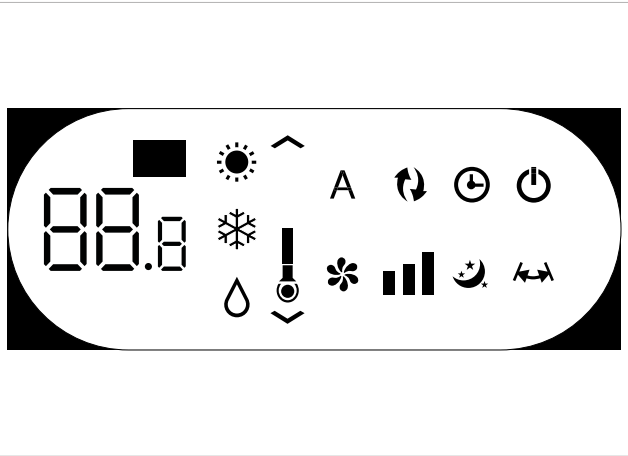

Related keys and functions

	Indicates the set point
	Increases the set temperature
	Decreases the set temperature
	Allows you to activate or put the appliance in stand-by
	Automatic function
	Allows the function in cooling mode only
	Function in dehumidification mode only.
	Allows the function in ventilation mode only
	Allows the function in heating mode only
	Nocturnal wellness key
	Allows control of the ventilation speed
	Allows you to set the timer function
	Digital thermometer 1=7 red bars in winter and blue in summer

4.2 Main functions

⚠ The buttons on the remote control and the touch screen display perform the same function.

Set the temperature

To set the room temperature

- ▶ press the keys to increase or decrease the desired value

The value shown on the display changes

⚠ The temperature adjustment range is from 16 to 31°C, with a resolution of 1°C.

⚠ Avoid setting the temperature too low or too high, as it can be detrimental to health and also leads to unnecessary energy waste.

Operation in ventilation mode only

To select the ventilation operation

- ▶ press and hold the button for approx. 2 seconds

The symbol on the display indicates that the Ventilation function is activated

By using this function, the appliance only activates the exhaust fan and does not take any action on the temperature or humidity of the ambient air.

It is possible to choose the fan speed.

Operation in cooling mode only

To select the cooling operation

- ▶ press and hold the button for approx. 2 seconds

The symbol on the display indicates that the Cooling function is activated

By using this function, the appliance dehumidifies and cools the air from the outside.

With a setpoint lower than the room temperature, the unit starts and begins to supply cold air, keeping the ventilation active even when the setpoint is reached.

Set the fan speed

To select the ventilation speed

- ▶ hold down the button

The symbol varies according to the ventilation speed in the following sequence:

Minimum

Medium

Maximum

Automatic (visible by scrolling the 3 speed bars on the display)

⚠ The higher the fan speed set, the greater the performance of the appliance, but the lower its quietness.

⚠ By setting the automatic fan speed, the onboard micro-processor independently adjusts the speed, keeping it higher as the deviation between the detected room temperature and the set temperature increases. The speed is automatically reduced as the room temperature approaches the set temperature.

⚠ In Dehumidification mode or Night Comfort mode, the control of fan speed is disabled as the unit can only operate at the minimum speed.

Automatic operation

To select the Automatic operation

- ▶ press and hold the button for approx. 2 seconds

the symbol lit indicates that the Auto mode is activated

⚠ The fan speed is automatically adjusted to achieve optimal comfort. The appliance automatically selects the

operating mode and fan speed based on the set temperature.

Operation in heating mode only

To select the heating operation

- ▶ press and hold the button  for approx. 2 seconds

The  symbol on the display indicates that the Heating function is activated

By using this function, the appliance heats the outside air. With a setpoint higher than the room temperature, the unit starts and begins to supply hot air.

Nocturnal operation

To select the nocturnal wellness operation

- ▶ press and hold the button  for approx. 2 seconds

The  symbol lit on the display indicates that the Nocturnal Wellness function is activated

- ⚠ The ventilation speed is automatically set to the minimum speed.
- ⚠ The set temperature varies automatically:
 - in heating mode, the set temperature decreases by 1°C after the first hour and by an additional degree in the second hour
 - in cooling mode, the set temperature increases by 1°C after the first hour and by an additional degree in the second hour
 - In both cases, after the second hour, the temperature setpoint will not be further altered, and after 6 hours, the unit will go into standby mode.
- ⚠ This function is not available for dehumidification-only and ventilation-only operation.
- ⚠ This function can be disabled at any time by pressing the button again.
- ⚠ If the Timer function is set simultaneously, the appliance will turn off when the set time expires.

Set the timer function

To set the timer function

- ▶ hold down the button  for 5 seconds





The  symbol on the display indicates that the Timer function is activated

This function allows you to schedule the activation or deactivation of the appliance.

To program the activation of the appliance

- ▶ with the display off, press the  key for 5 seconds

The  symbol on the display indicates that the Timer function is activated

- ▶ select with the arrows   the number of hours (from 1 to 24 h) after which the appliance will be switched on automatically
 - ▶ press the button again  to confirm the operation
- The display lights up completely, showing the settings (setpoint, active functions, etc.) that will be activated when the appliance is turned on automatically.*
- ▶ press the button again  to confirm the operation

To program the device to turn off.

Set the key lock

To set the key lock

- ▶ press and hold the button  for approx. 10 seconds

The display lights up entirely, showing the active settings, and the  flashes with a frequency of 1 second

Any action is prevented from the user

To deselect the key lock

- ▶ press and hold the button again  for approx. 10 seconds

The display lights up entirely, showing the active settings, and the  button remains fixed.

To deactivate/put the control unit in standby mode

To deactivate/put the control unit in standby mode

- ▶ press and hold the button  for approx. 2 seconds

The control panel switches off

- ⚠ The control system of the appliance is equipped with memory, so all settings will be retained in case of power loss or shutdown (except for ventilation).
- ⚠ In stand-by mode, the control system ensures anti-freeze protection.
- ⚠ In case of extended shutdown of the appliance, it should be deactivated by disconnecting the main switch or removing the plug from the power outlet.

4.3 Warnings

Alarm display

- ⚠ In case of an appliance malfunction, an alarm code is displayed on the screen.
- ⚠ In case of an alarm, the appliance still maintains some active functions.

E 1 Faulty room temperature sensor (RT)

E 2 Faulty internal battery sensor (IPT)

E 3 Faulty outdoor air temperature sensor (OT)

E 4 Faulty external battery sensor (OPT)

E 5 Faulty indoor fan motor

E 6 External air fan malfunction

E 7 Lack of communication with the display

E 8 Compressor discharge sensor faulty

CP Open contact for presence detection (CP)

 flashing Unsuitable water temperature
In heating mode, the water temperature is lower than 30°C

 flashing Unsuitable water temperature
In cooling mode, the water temperature is higher than 20°C

Management of the device in case of unavailability of the remote control

Problem diagnosis

It is important for the user to be able to distinguish between any malfunctions or functional anomalies and the expected behavior of the device during its normal operation.

Most common issues can be easily resolved by the user through simple operations, while for some alarms displayed on the screen, it is necessary to contact the Customer Support Service.

 Any attempt of repair carried out by unauthorized personnel immediately voids any form of warranty.

5. START-UP

5.1 Preliminary warnings

- ⚠ **This section is dedicated to the Authorised Service Centre. The specifications of the Authorised Service Centre are described in chapter "Recipients" p. 4.**
- ⚠ **Initial commissioning must be carried out by the Authorised Service Centre.**
- ⚠ **For detailed information on accessories, please refer to the relevant instruction sheets.**
- ⚠ The customer must be present when the appliance is tested and informed of the contents of the manual and procedures. After commissioning, the manual and the warranty certificate must be handed over to the customer.
- ⚠ Before start-up, all works (electrical, hydraulic and air-flow connections) must have been completed.
- ⚠ The unit allows for air exchange and energy recovery with the heat pump, which can integrate heating, cooling, and dehumidification of the environment. It cannot independently perform the functions of heating and cooling.

Preliminary warnings for R32

- ⚠ The unit uses R32 refrigerant, with a Global Warming Potential (GWP) of 675. Do not release R32 gas into the atmosphere.
- ⚠ The R32 refrigerant gas is mildly flammable and odourless.
- ⚠ All precautions regarding the handling of refrigerant must be followed in accordance with current regulations.
- ⚠ Avoid proximity to continuously operating ignition sources (open flames, gas appliances, electric stoves, lit cigarettes, etc.).
- ⊖ It is prohibited to use means to speed up the defrosting process or for cleaning other than those recommended.
- ⊖ Smoking is prohibited near the appliance.

- ⊖ The use of mobile phones is prohibited near the appliance.
- ⊖ It is forbidden to introduce objects and substances through the openings provided for the intake and delivery of air.

⚠ Perform the following checks:

- Perform safety checks to ensure that the risk of combustion is minimised
- avoid working in confined spaces
- delimit the area around the workspace
- ensure safe working conditions around the area by checking for flammable materials

Leak detection

- ⊖ Using combustion-based refrigerant fluid detectors, such as a halide torch or any other system using an open flame, is prohibited.
- ⚠ For leak detection, follow the following instructions:
 - use electronic detectors to search for flammable refrigerant fluids
 - before usage, ensure the detectors are properly calibrated
 - calibration operations must be carried out in an area free from refrigerant fluid
 - ensure the detector is not a potential ignition source and is suitable for the refrigerant fluid used
 - if a leak is suspected, all open flames must be eliminated
 - in the event of a leak requiring brazing, it is mandatory to recover all refrigerant fluid from the system or isolate it (using shut-off valves) in a part of the system away from the leak
- ⚠ The use of silicone sealant can compromise the effectiveness of certain types of leak detection instruments.

5.2 First start-up

Preliminary Checks

Before commissioning, check that:

Operational checks

- all safety conditions have been met
- the unit has been properly secured to the supporting surface or wall
- the minimum technical spaces have been observed

Airflows

- the airflow connections have been made according to the instructions in the manual
- all airflow connections are correctly secured
- the ducting is correctly supported
- the ducting does not have any bottlenecks
- the ducting is thermally insulated

Electrical checks

- the cross-section of the power supply cables is adequate for the absorption of the appliance and the length of the connection made
- grounding is correctly performed
- the electrical connections have been established correctly
- all control wires are connected and that all electrical connections are secure

Start-up

After all checks have been carried out, the unit can be put into operation.

To activate the appliance:

- ▶ please refer to the user manual

Checks with the machine switched on

After starting up, check that

Operational checks:

- verify the different modes of operation
- verify that the appliance stops and then restarts
- switch the appliance off and on again and check that it restarts correctly
- the appliance operates within the recommended operating conditions (see technical specifications table)
- check that the air flow rates are correct

Hydraulic Checks

- check for proper condensate drainage

Electrical Checks

- the current absorbed is less than the maximum indicated in the technical data table
- the supply voltage value is within the set limits and does not fall below the nominal value -10 % during operation

5.3 Plant delivery

Once all the checks and controls on the correct operation of the plant have been completed, the installer must explain the following to the user:

- the basic functional characteristics of the appliance
- the instructions for use
- the routine maintenance

5.4 Switching off for extended periods

If the appliance is not used for a long period of time, the following steps must be taken:

- ▶ deactivating the device
- ▶ isolate the power supply
- ⚠ To restart the appliance after it has been out of use for a long period, call in the Authorised Service Centre.

6. MAINTENANCE

6.1 Preliminary warnings

Before any cleaning or maintenance intervention:

- ▶ Disconnect the device from the electrical network by setting the main switch of the system to "OFF"
- ▶ wait for the components to cool down to avoid the risk of burns

- ⊘ Any technical or cleaning intervention is prohibited before disconnecting the unit from the power supply.
- ⚠ Check for the absence of voltage before performing any operation.
- ⚠ After performing the necessary maintenance operations, restore the original conditions.
- ⚠ Handle the refrigerant with care. Leaking refrigerant can cause frostbite.

6.2 Routine maintenance

The routine maintenance plan includes the following cleaning operations.

External cleaning

Clean the external surfaces of the appliance with a soft cloth dampened with water.

- ⚠ Before any cleaning or maintenance intervention, disconnect the unit from the electrical network by turning

off the main power switch or unplugging the power plug.

- ⚠ Do not use abrasive sponges or abrasive or corrosive detergents to avoid damaging the painted surfaces.

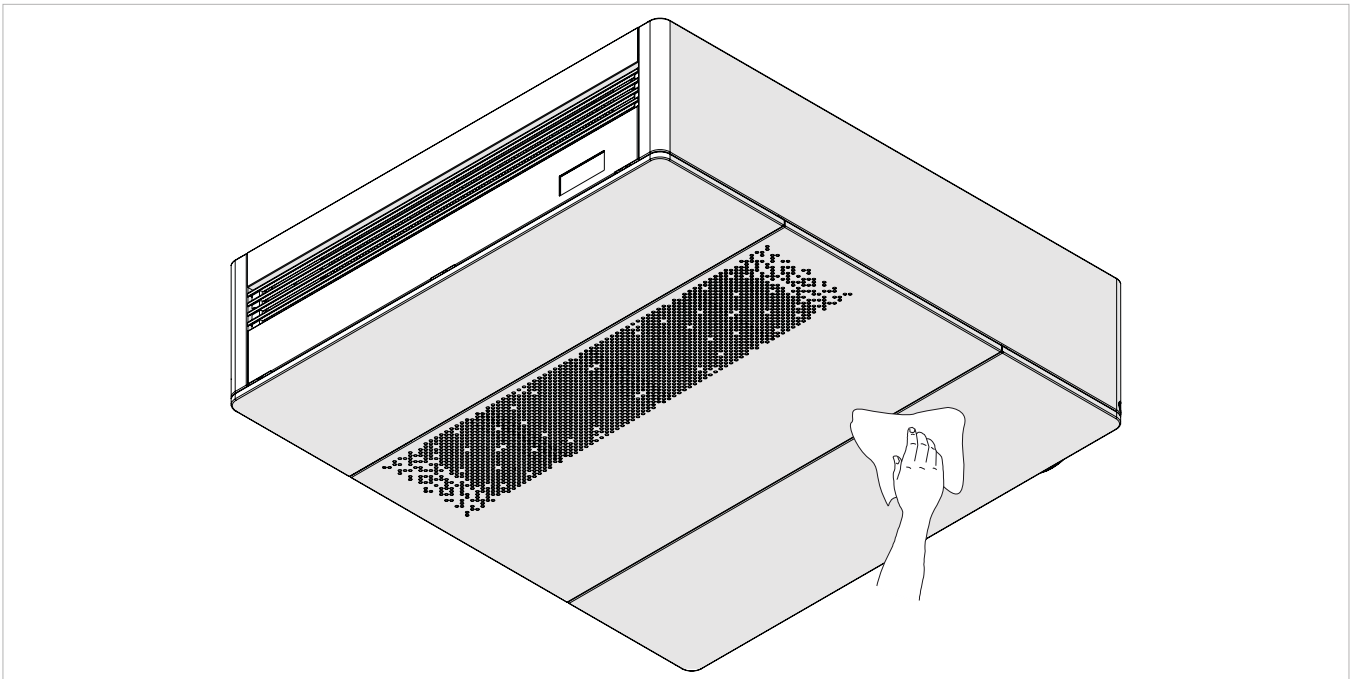

Cleaning or filter replacement

⚠ Pay attention to sharp surfaces

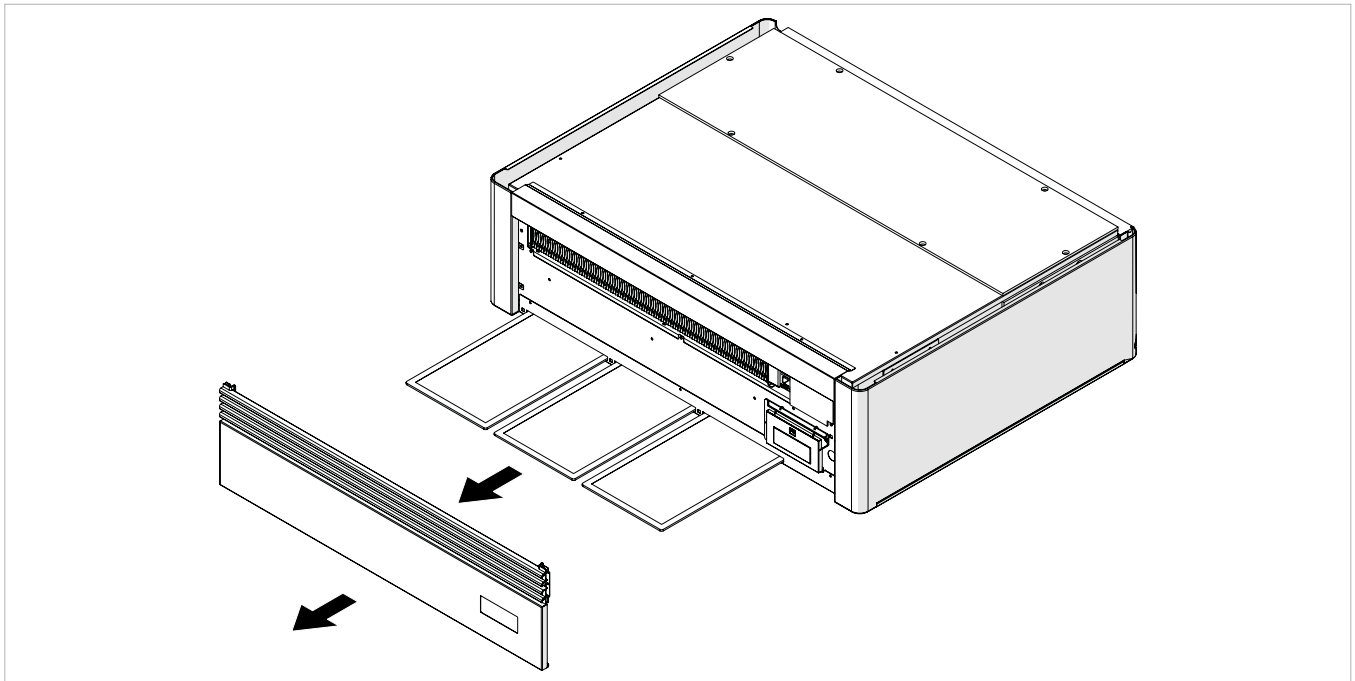

To remove the filters:

- ▶ turn off power to the unit by unplugging the plug
- ▶ remove the grille and lower front panel (see chapter "Unit preparation" p. 15)
- ▶ gently pull the filter towards yourself
- ▶ take out the filter
- ⓘ **If the condition of the filters is acceptable, they can be cleaned using a vacuum cleaner or a low-pressure compressor.**
- ⓘ **If it is impossible to clean them, the filters must be replaced.**

To reposition:

- ▶ perform in reverse order

7. FAULTS AND REMEDIES

7.1 Preliminary warnings

If one of the following faults is found:

- ventilation does not activate
- the appliance makes excessive noise
- there is dew formation on the front panel

Follow the instructions below:

- ▶ immediately isolate the power supply
- ▶ contact an Authorised Service Centre or professionally qualified personnel
- ⚠ The intervention must be carried out by a qualified installer or an Authorised Service Centre.
- ⊘ Personal intervention is prohibited.

7.2 Troubleshooting table

DESCRIPTION OF FAULT	CAUSE	REMEDY
Display off	No power supply (light switch off)	Check the electrical connection to the power supply
Low or absent air flow	Clogged filters	Replace filters
The rooms remain humid		
High noise level	Clogged heat exchanger	Clean the heat exchanger
	Dirty fan	Clean the fan
	Clogged fan ducts	Clean the ventilation ducts
	Outdoor temperature below 0°C	The unit may be in anti-freeze mode. Wait until the outside temperature increases or consider installing a pre-heating electric heater
	Noise coming from the unit	Check for the presence of gaps and/or air leaks from the unit's panels Check the siphon connection Check if the motors are running correctly (bearings)
High vibrations	Noise coming from the ducts	Check for the presence of cracks on the intake/exhaust ducts
	Vibrating panels	Check the integrity of the panels and aluminum profiles of the unit
		Check the proper closure of the unit's cover and the panel covering the electronic board
	Imbalanced fan blades	Check that there are no walls that could transmit vibrations to the wall/floor/ceiling
Check the integrity of the fan blades Clean the fans Check that the small metal clips for balancing the fan blades are still present on the fans		
Condensate leak	Clogged condensate drain	Clean condensate drain
	The condensation does not flow from the drainage pipe into the collection tray	Check that the unit is perfectly level
		Check that the condensate drain connections are not clogged
		Verify that the siphon has been properly constructed

DESCRIPTION OF FAULT	CAUSE	REMEDY
The appliance does not turn on	No power supply	Check if there is mains voltage (by turning on a household lamp, for example) Check that the potential exclusive circuit breaker protecting the device has not tripped (if it has, reset it). If the issue repeats immediately, contact the Authorised Service Centre without attempting to operate the device.
The appliance does not cool/heat sufficiently	The set temperature is too high or too low	Check and adjust the temperature setting if necessary
The appliance does not cool/heat sufficiently	The set temperature is too high or too low	Check and adjust the temperature setting if necessary
	The air filter is clogged	Check the air filter and clean it if necessary
	Check for any obstructions to the airflow inside or outside	Remove anything that could obstruct the airflow

7.3 Table of alarms indicated by the display

ALARM	CAUSE	OPERATION
E1	Fault ambient temperature sensor RT	It is possible to activate regularly the functions Heating, Cooling, and Dehumidification. The regulation monitors only the antifreeze of the internal battery
E2	Fault internal battery sensor IPT	It is not possible to activate any operation of the device
E3	Fault external air temperature sensor OT	It is not possible to activate any operation of the device
E4	Fault external battery temperature sensor OPT	It is possible to activate regularly the Heating, Cooling, and Dehumidification functions. The regulation performs defrost cycles at fixed intervals
E5	Fault internal air fan motor	It is not possible to activate any operation of the device
E6	Fault external air fan	It is not possible to activate any operation of the device
E7	Lack of communication with the display	It is not possible to activate any operation of the device
E8	Faulty compressor discharge sensor	It is not possible to activate any operation of the device
CP	Open contact for presence detection (CP)	The appliance does not activate. Check the connection of the terminals

8. TECHNICAL INFORMATION

8.1 Technical data

Models	u.m.	2.0 CEILING
Cooling performance (A 35; A 27) EN 14511 (1)		
Dual Power maximum cooling capacity	kW	3,05
Nominal cooling capacity	kW	2,25
Minimum cooling capacity	kW	1,10
Dehumidification capacity	L/24h	0,90
Total absorbed power	W	700
EER		3,21
Heating performance (A 7; A 20) EN 14511 (2)		
Dual Power maximum heat output	kW	3,00
Nominal heat output	kW	2,21
Additional power electric resistance	kW	0,90
Minimum heat output	kW	0,94
Total absorbed power	W	700
COP		3,16
Air recirculation filter		
Type		Nylon flat filter
Number	No.	3
Electrical characteristics		
Power supply	V / ph / Hz	230 / 1 / 50
Maximum total absorbed power	W	1150
Maximum total absorbed current	A	5,10
Room side sound levels (UNI EN 3741; 3744) (3)		
Sound power transmitted to the Lw structure	dB (A)	62,0
Average sound pressure at 1 m Lp	dB(A)	48,0
Average sound pressure at 3 m Lp	dB(A)	40,0
Compressor		
Type		Rotary DC inverter
Number	No.	1
Refrigerant type		R32
Refrigerant quantity	kg	0,50
Product dimensions		
1. External air temperature 35°C, relative humidity 41%. Ambient temperature 27°C; relative humidity 47%. Performance according to EN 14511 2. External air temperature 7°C; relative humidity 87%. Ambient temperature 20°C, relative humidity 59% (max). Performance according to UNI 14511 3. Data refers to the UNI EN 3741 and UNI EN 3744 standards		

Models	u.m.	2.0 CEILING
Width	mm	1093
Length	mm	823
Height	mm	314
Wall hole diameter	mm	160
Empty weight	kg	69
<p>1. External air temperature 35°C, relative humidity 41%. Ambient temperature 27°C; relative humidity 47%. Performance according to EN 14511</p> <p>2. External air temperature 7°C; relative humidity 87%. Ambient temperature 20°C, relative humidity 59% (max). Performance according to UNI 14511</p> <p>3. Data refers to the UNI EN 3741 and UNI EN 3744 standards</p>		

8.2 Dimensions

- 1. Power supply
- 2. Condensate drain

- 3. Female flange Ø 160 mm (optional)
- 4. Fixing holes

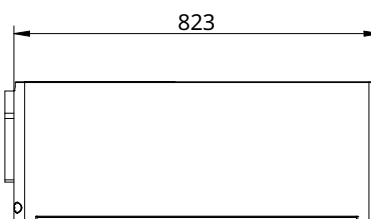
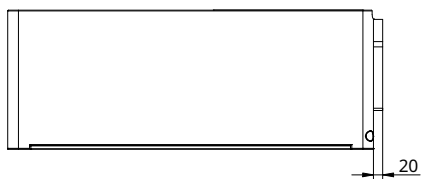
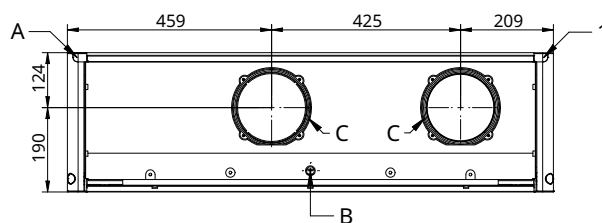
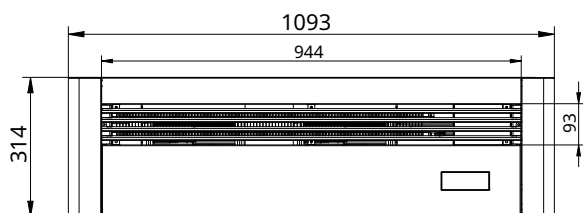
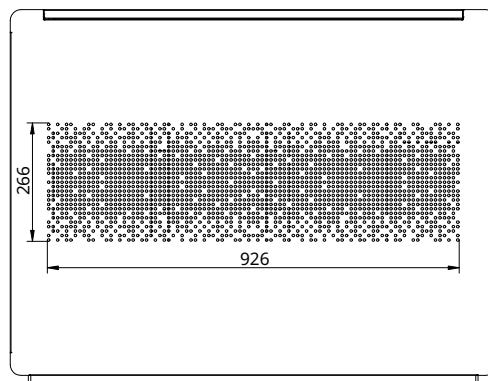
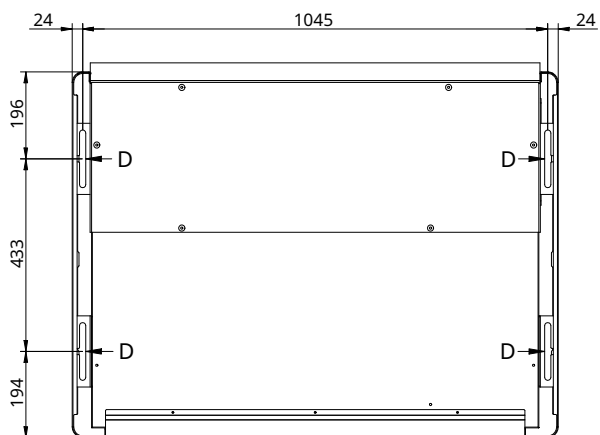



innova

INNOVA S.r.l.
Via I Maggio 8 - 38089 (TN) - ITALY
tel. +39.0465.670104 - fax +39.0465.674965
info@innovaenergie.com